













LEGEND

	Rundown Barrel (with slash marks)
	Random Barrel (without slash marks)
	Light Target
	Dark Target
	A target on a short stick
	TOB Top of Barrel rule: If a target is set on top of a barrel it may be engaged either coming into our going out of the turn without a penalty. This is indicated by TOB
	First Target Rule: Must be engaged first, random course requirements begin after this target.
	Last Target Rule: Must be engaged last.
	Gate: you must pass between these two objects. This may be done from either direction.
	You may go around the object from either direction
	You must follow direction of the arrow.
	Object may be shot from either side. You may go between objects from either direction.
	Full Barrel Turn: May be turned either direction, unless specified in course description.
	TTR Two Target Rule: If a contestant hits two targets with one shot they may use the remaining round to pick up any target they may have missed.

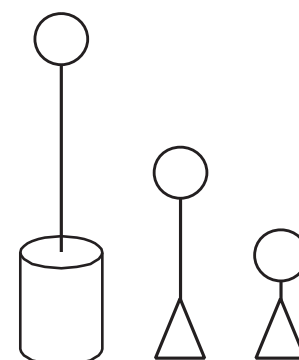

COURSE OF FIRE INSTRUCTIONS

- TTR 2-Target Rule: If two targets are burst by gun fire, of same or different color, it will not be a miss and poles do NOT have to be engaged. The extra round may be used to engage a missed target.
- Gate Rule: Targets do NOT have to be engaged going through a gate. Competitor must pass through the gate from either side. Horse's entire body must pass through gate - tails do not count.
- Targets should be a minimum distance of 12' from any barrel.
- TOB Rule: If a target must be set on top of a barrel, it may be engaged going in to or coming out of the barrel (this includes the Rundown barrel).
- Rounding a Barrel: Does not mean crossing your path or a 360° turn.
- Full Barrel Turn: Means crossing your path or a 360° turn.
- A competitor may go back and round a barrel or pick up a gate to avoid a penalty.
- Standard spacing for a Rundown target is 36 feet.
- A standard Gate is 15 feet.
- Rundown is a straight line, may be engaged from either side and may be gone between.
- Targets may be engaged in any order, from either side, unless specifically noted.
- An ideal arena is 200 feet by 300 feet. Distance between the targets and barrels may be shortened to accommodate a smaller arena.
- It is each club's responsibility to ensure arena safety. If, for any reason, a competitor is concerned about the safety of an arena, they should withdraw from competition. Competitors enter at their own risk.
- If a competitor is engaging the last rundown balloon while crossing the timer there shall be no penalty if there is forward motion.

Only Courses in the CMSA Rulebook may be used at WPQ Matches.

The course of fire or pattern of riding is commonly referred to as a stage and should be designed for maximum enjoyment of competitors and spectators, while safely testing horsemanship and shooting skills. The safety of competitors, spectators and horses is a principle concern.

The primary purpose of a stage is to provide a scoring grid that is fair for all competitors. A standard CMSA stage is to have ten targets. It is not the specific intention of the CMSA rules to penalize a fast horse and competitor. After completing the stage, the competitor shall immediately unload both revolvers.

Instructions

- A. Engage the farthest light targets first.
- B. Engage the entire Random course first, then round the Random barrel.
- C. Engage 5 of one color, round the barrel(s), engage 5 of the other color.
- D. Engage 10 targets in any order.
- E. Engage all light targets first, then round the Rundown barrel.
- F. Engage 5 of one color, then engage 5 of the other color.
- G. Engage all the light targets first. Then engage the dark targets. You must round the barrel.
- H. Engage the entire Random course first, then round the Rundown barrel.

Penalties

1. Missed target: 5 seconds
2. Knocked over barrel: 5 seconds
3. Dropped gun: 5 seconds
4. Failure to holster: 5 seconds
5. Non Qualified run or maximum time on any run: 60 seconds
6. Unsafe gun handling: 5 second per occurrence
7. Loss of hat prior to engaging the course of fire: 10 seconds
8. Knocking over a gate cone or missing a gate: 10 seconds
9. Failure to round the Random Barrel: 15 seconds
10. Engaging designated "First" or "Last" targets out of order per course of fire instructions: 15 seconds

Procedurals

1. Failure to engage the targets in proper order.
2. Failure to engage all of the correct targets before rounding the barrel.
3. Failure to round barrel.

Notes

- When in doubt, favor the competitor.
- There is only ONE Procedure per stage.
- If a competitor corrects his/her mistake, there is no procedure.
- Random course indicates light targets.
- When the instructions indicate to complete the Random course BEFORE rounding the Rundown barrel the parts of the Random course may be completed in ANY order PRIOR to rounding the Rundown barrel.
- When the instructions indicate that a particular portion of the course is to be completed prior to rounding either the Rundown or Random barrel it shall be a procedural if any portion of that (targets, gates, barrels etc) are completed after rounding the appropriate barrel.
- If the course includes a Rundown barrel, the competitor shall round the Rundown barrel prior to engaging any targets in the Rundown.
- Course numbers are not in strict numeric order because historic statistical data is being stored based upon course numbers.

COURSES OF FIRE

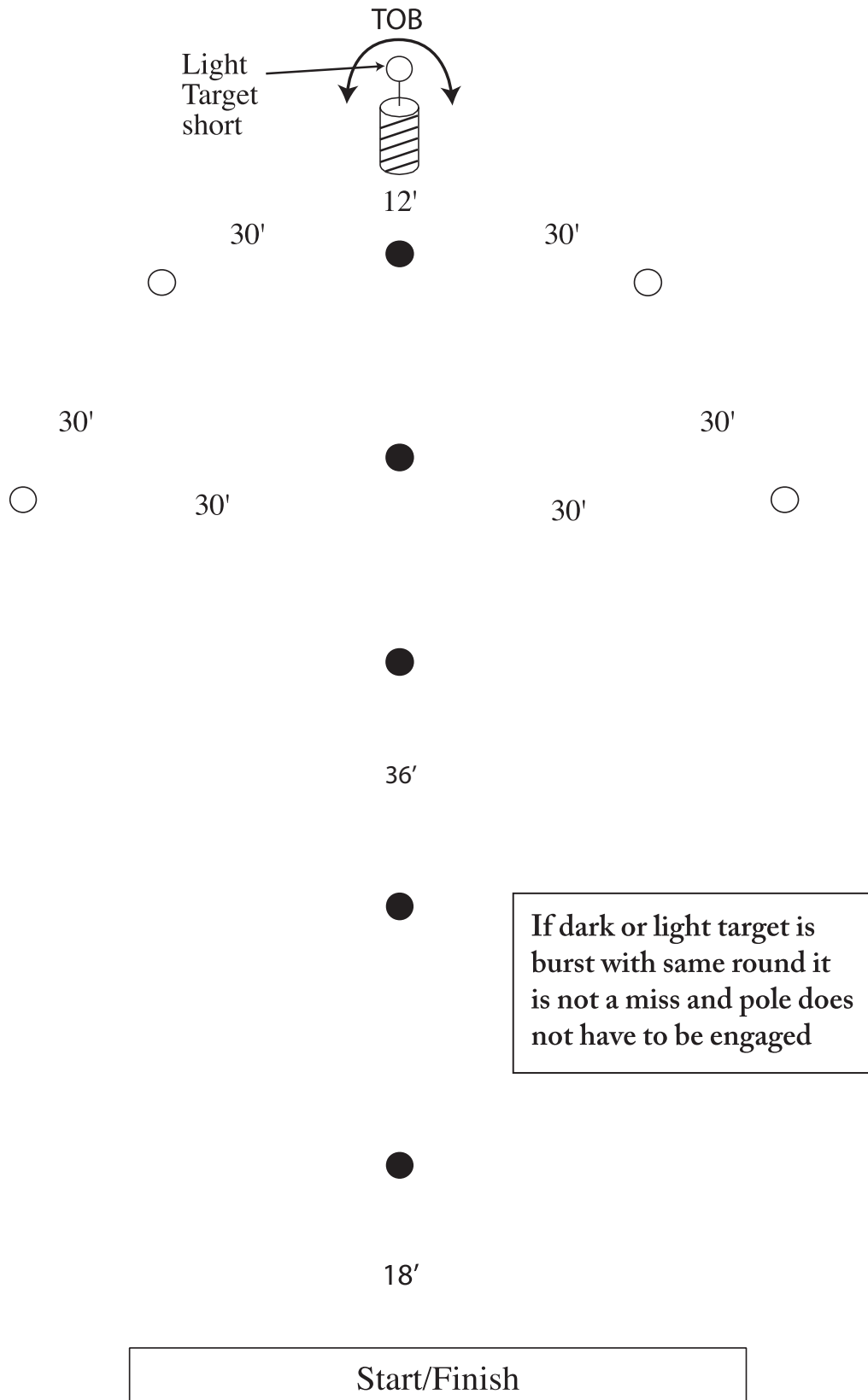

#1 The Arrow

E. Engage all light targets first, then round the Rundown barrel.

Procedurals: 2, 3

Rifle/Shotgun Course

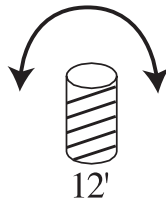

Targets may be engaged from either side or rider may go between poles.



31'

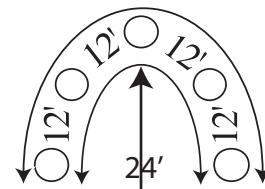

36'

30'



18'

Start/Finish

#3

B. Engage the entire Random course first, then round the Random barrel
 Procedurals: 2, 3

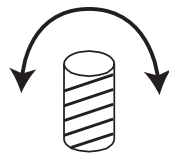

12'



Targets may be engaged from either side or rider may go between poles.

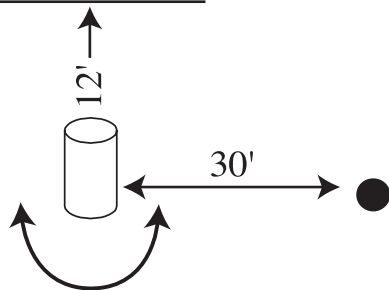
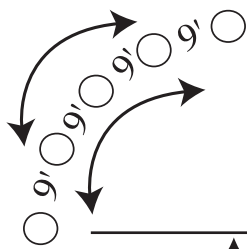

36'



18'

Start/Finish

#4

B. Engage the entire Random course first, then round the Random barrel
Procedurals: 2, 3

Targets may be engaged from either side or rider may go between poles.

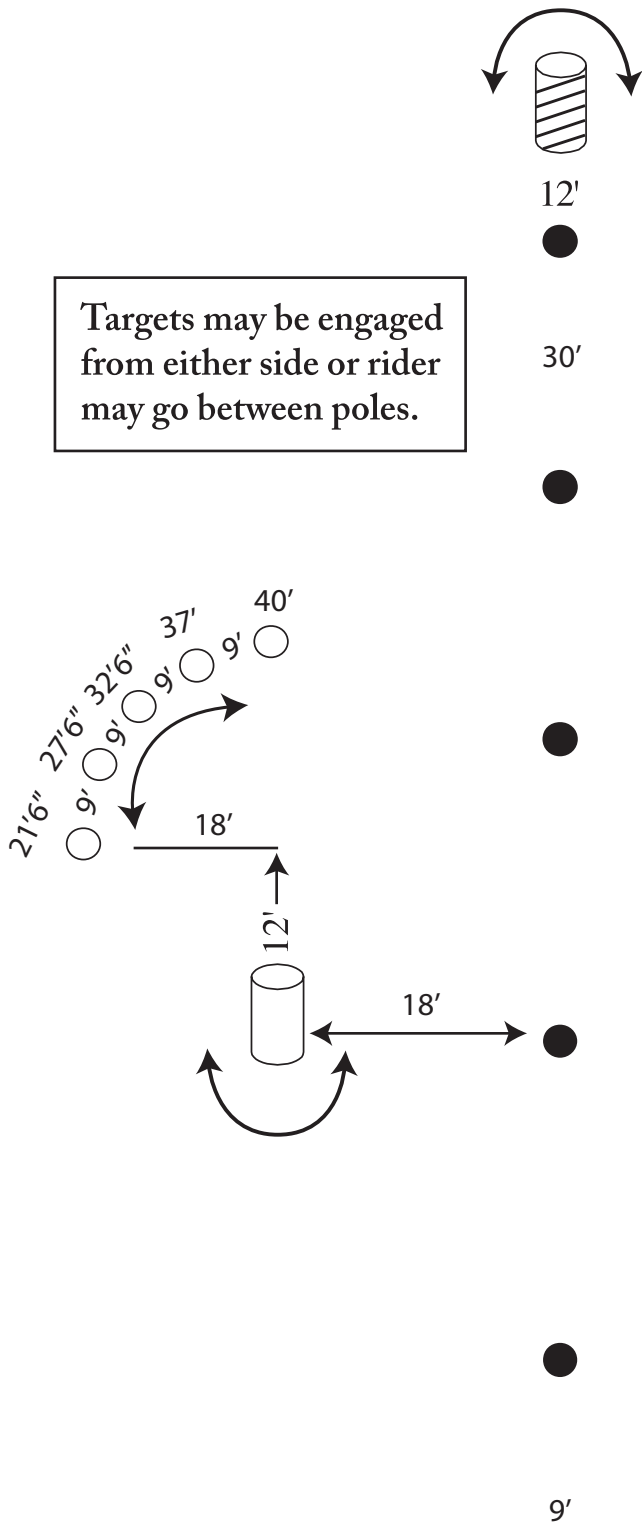

Start/Finish

#4s

B. Engage the entire Random course first, then round the Random barrel
 Procedurals: 2, 3

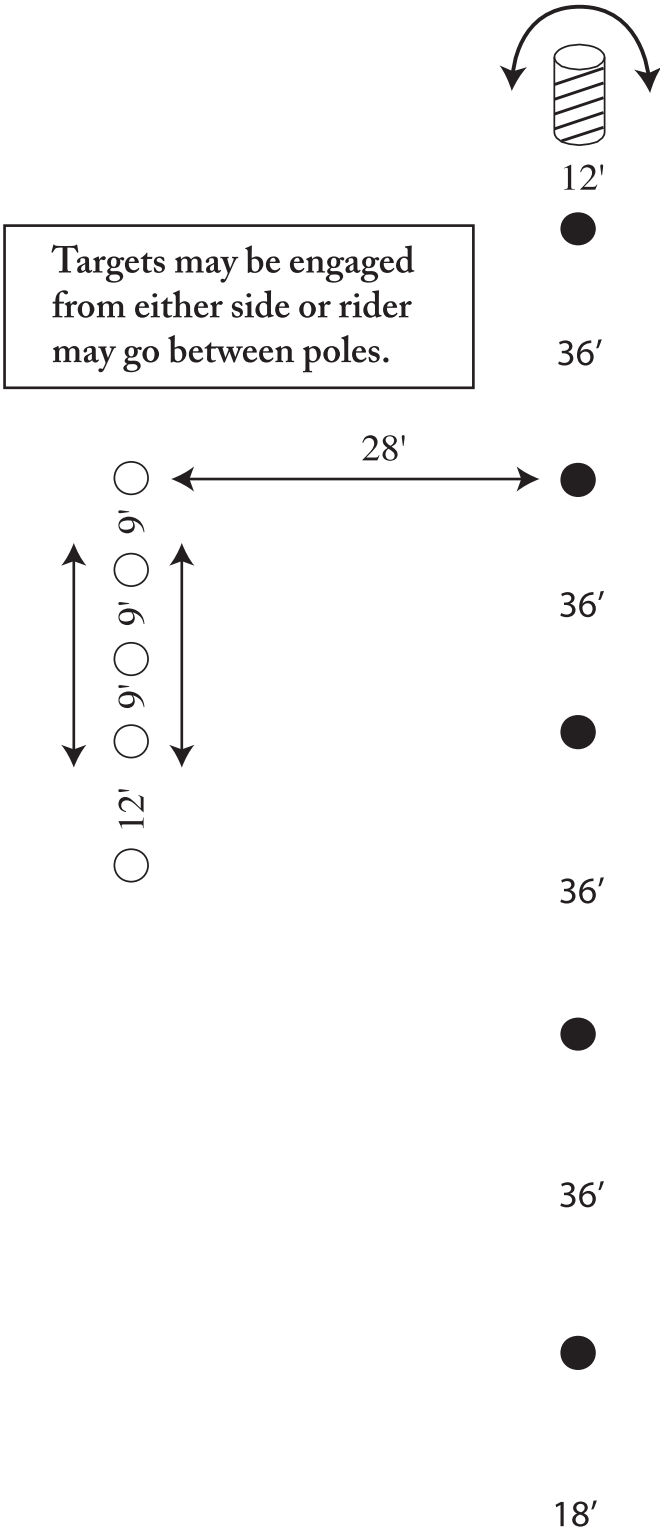

----- Timer

H. Engage the entire Random course first, then round the Rundown barrel.
 Procedurals: 2, 3

Course 5 - Certified

Targets may be engaged from either side or rider may go between poles.

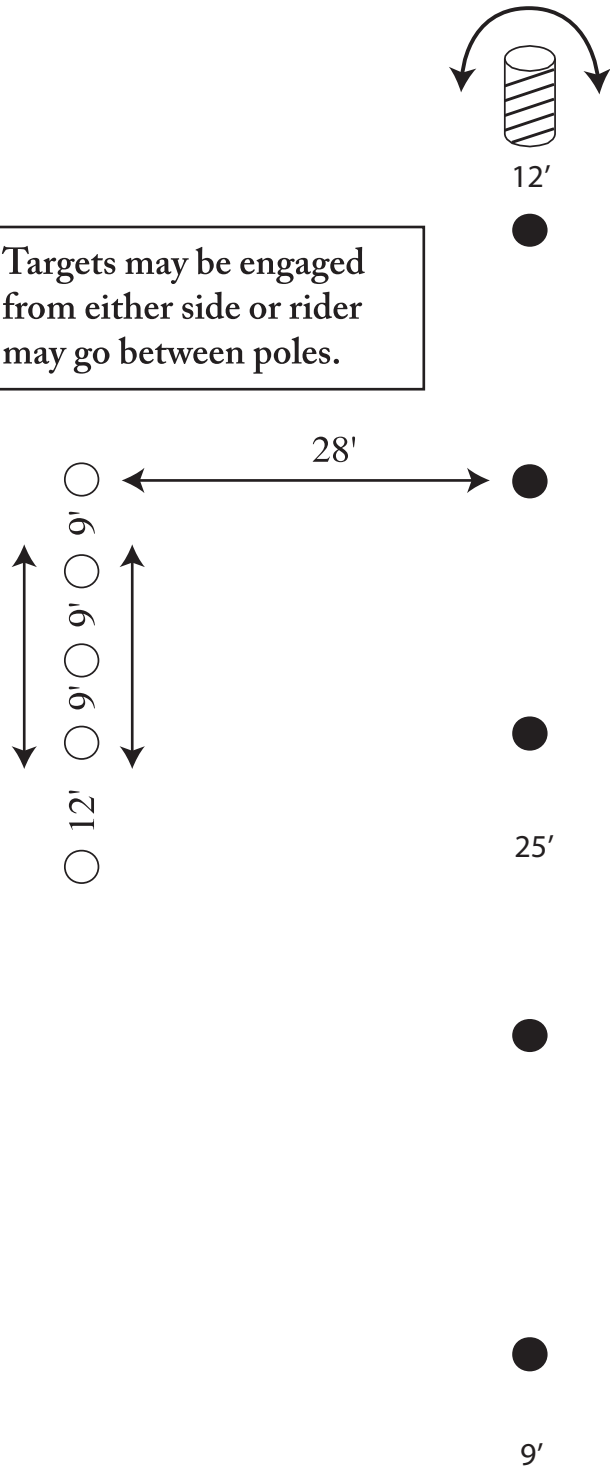

----- Timer

E. Engage all light targets first, then round the Rundown barrel.
Procedurals: 2, 3

Course 5ss - Certified

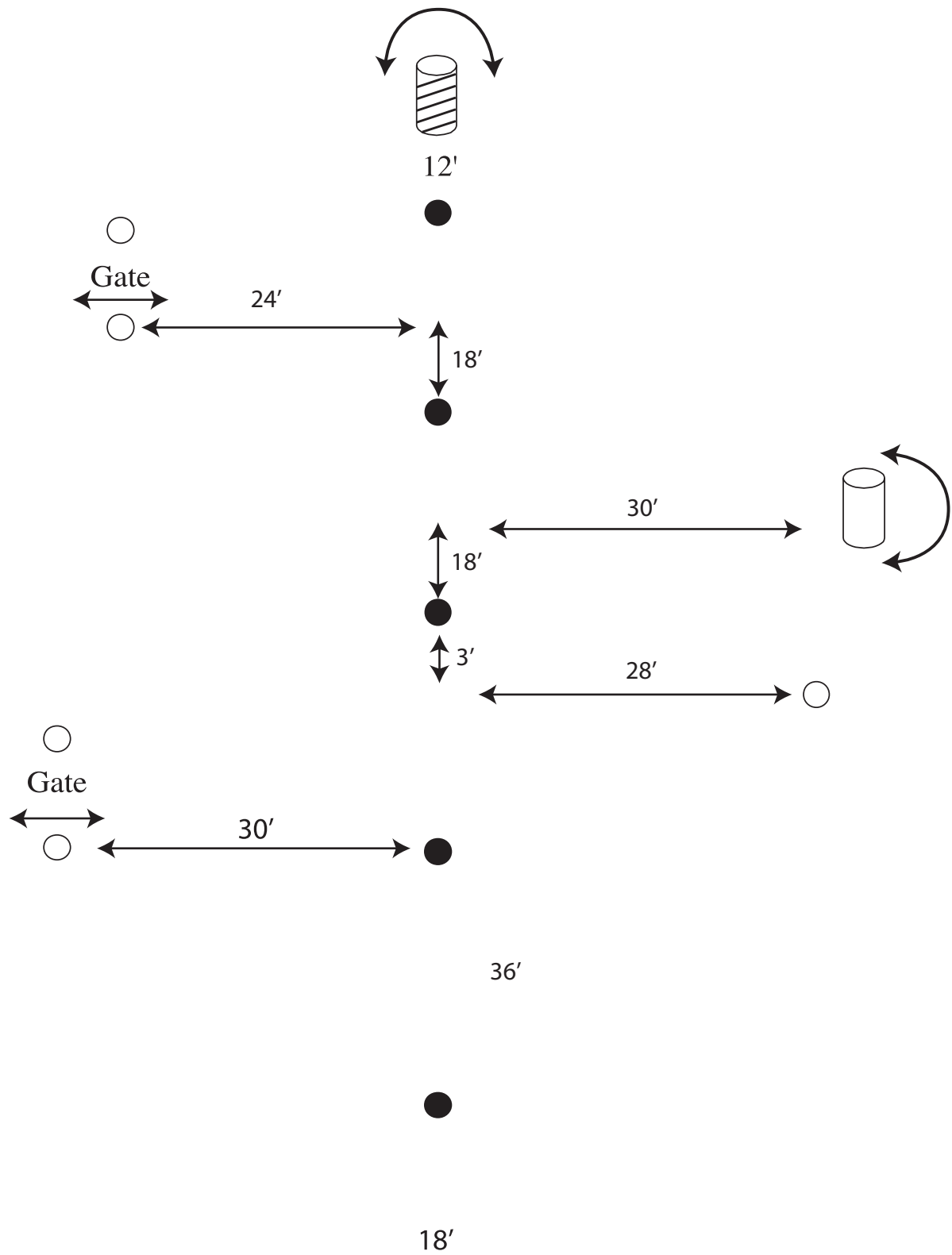

Start/Finish

#6

H. Engage the entire Random course first, then round the Rundown barrel.
 Procedurals: 2, 3

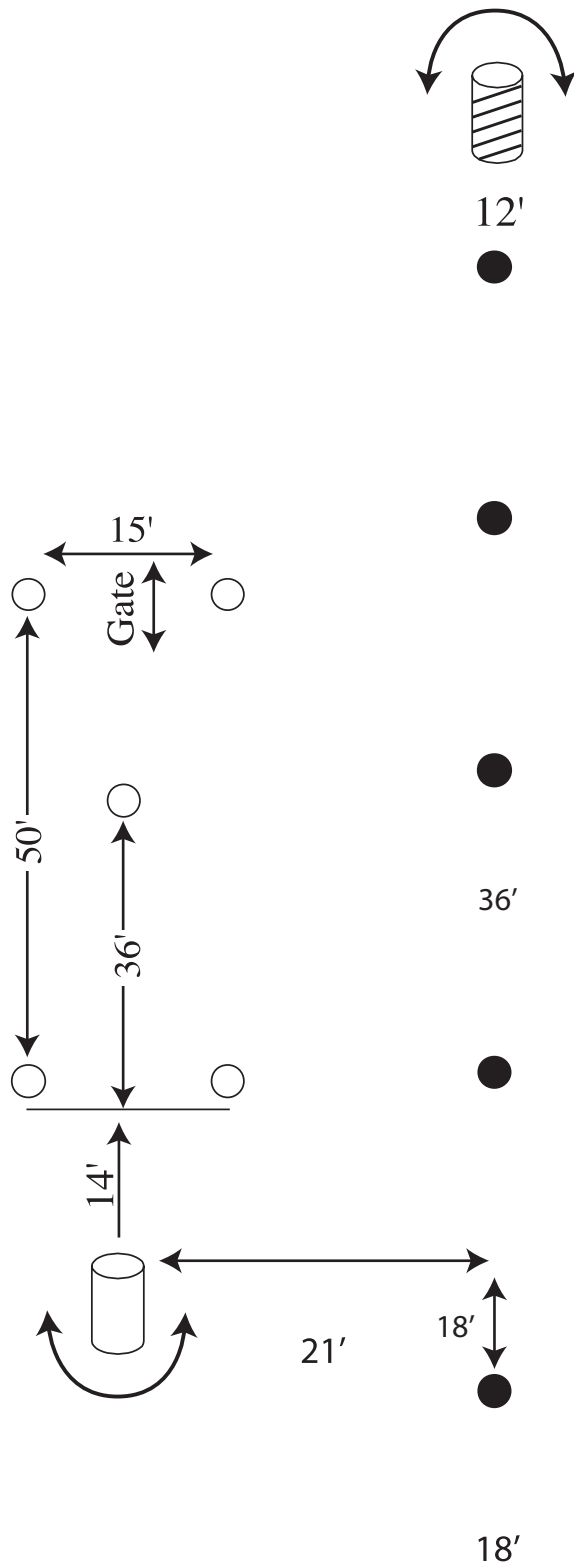

Start/Finish

#7

B. Engage the entire Random course first, then round the Random barrel
 Procedurals: 2, 3

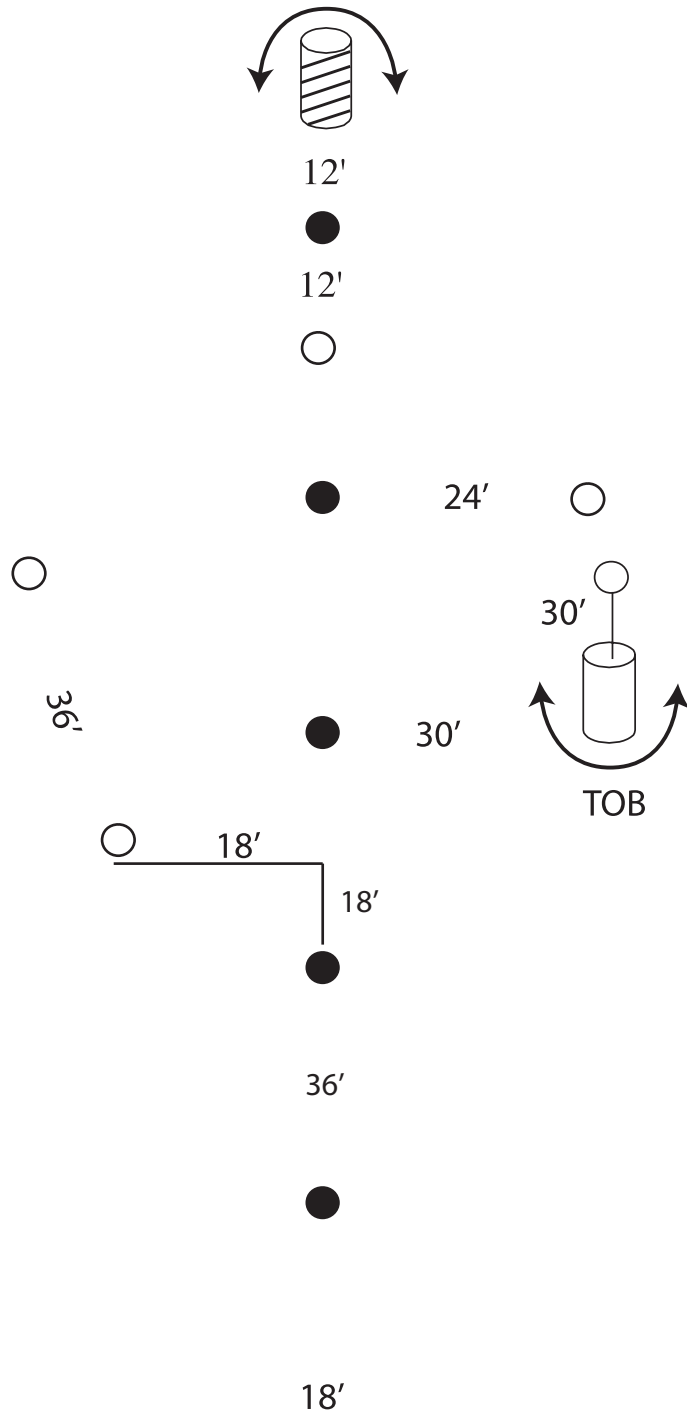

Start/Finish

#9

B. Engage the entire Random course first, then round the Random barrel
 Procedurals: 2, 3

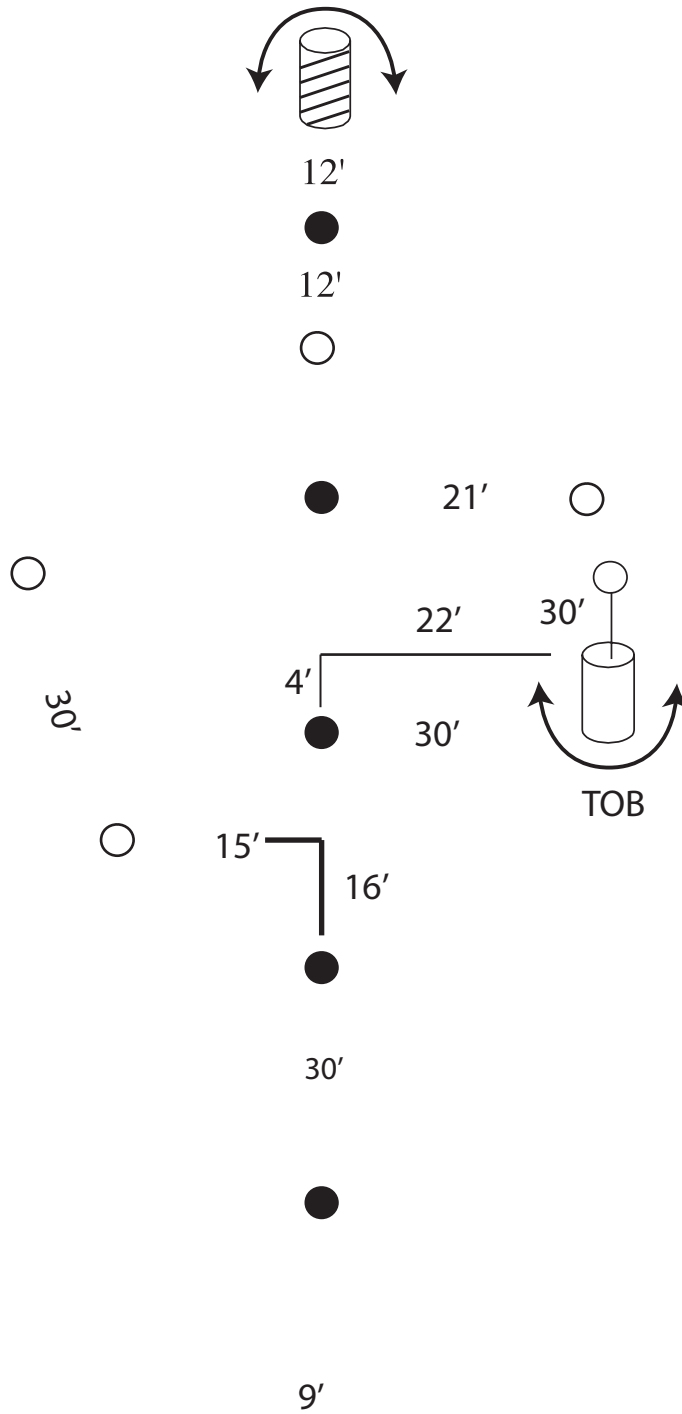

Start/Finish

#9s

B. Engage the entire Random course first, then round the Random barrel
 Procedurals: 2, 3

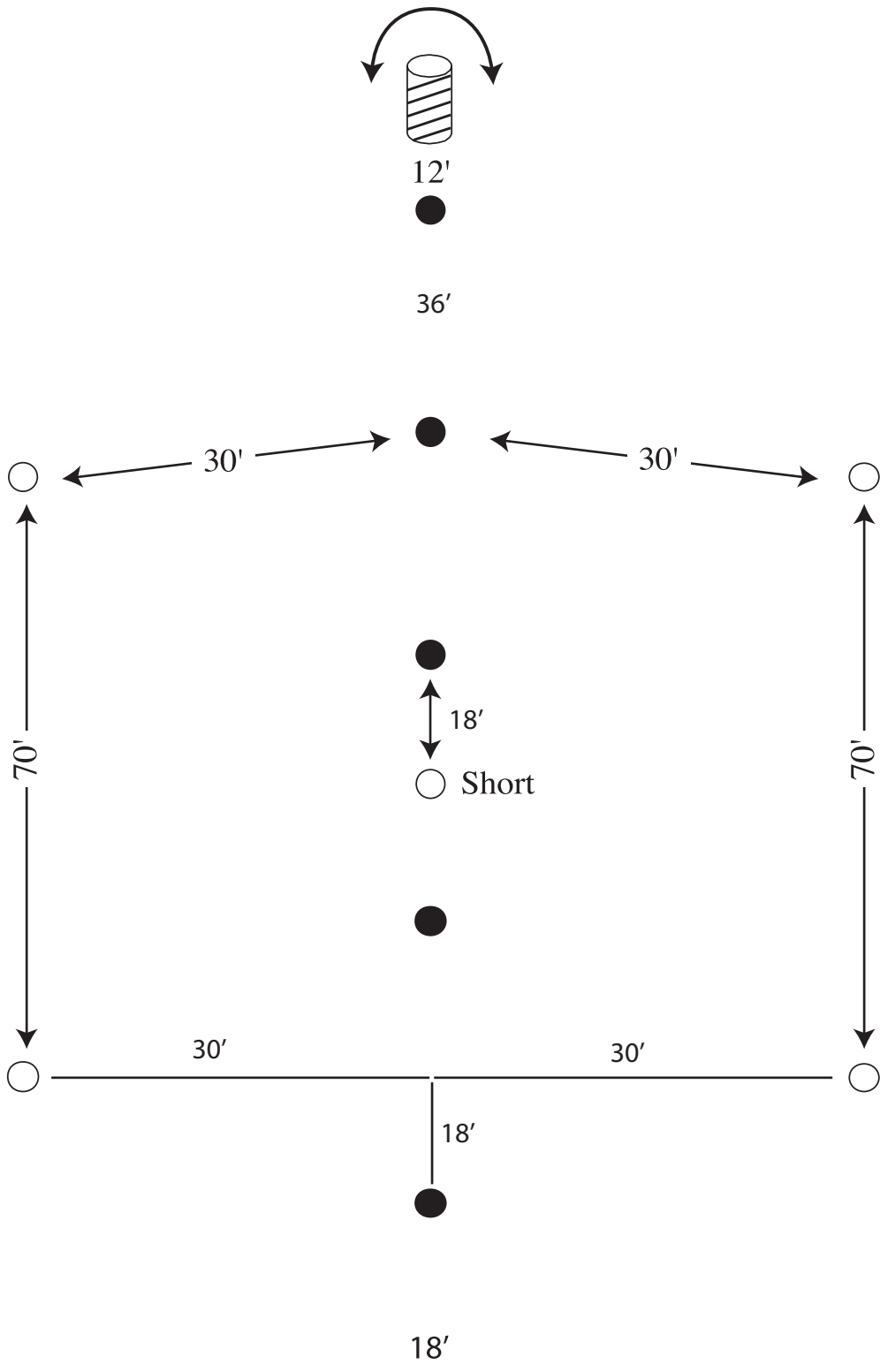

Start/Finish #10

E. Engage all light targets first, then round the Rundown barrel.
 Procedurals: 2, 3
 Rifle/Shotgun Course

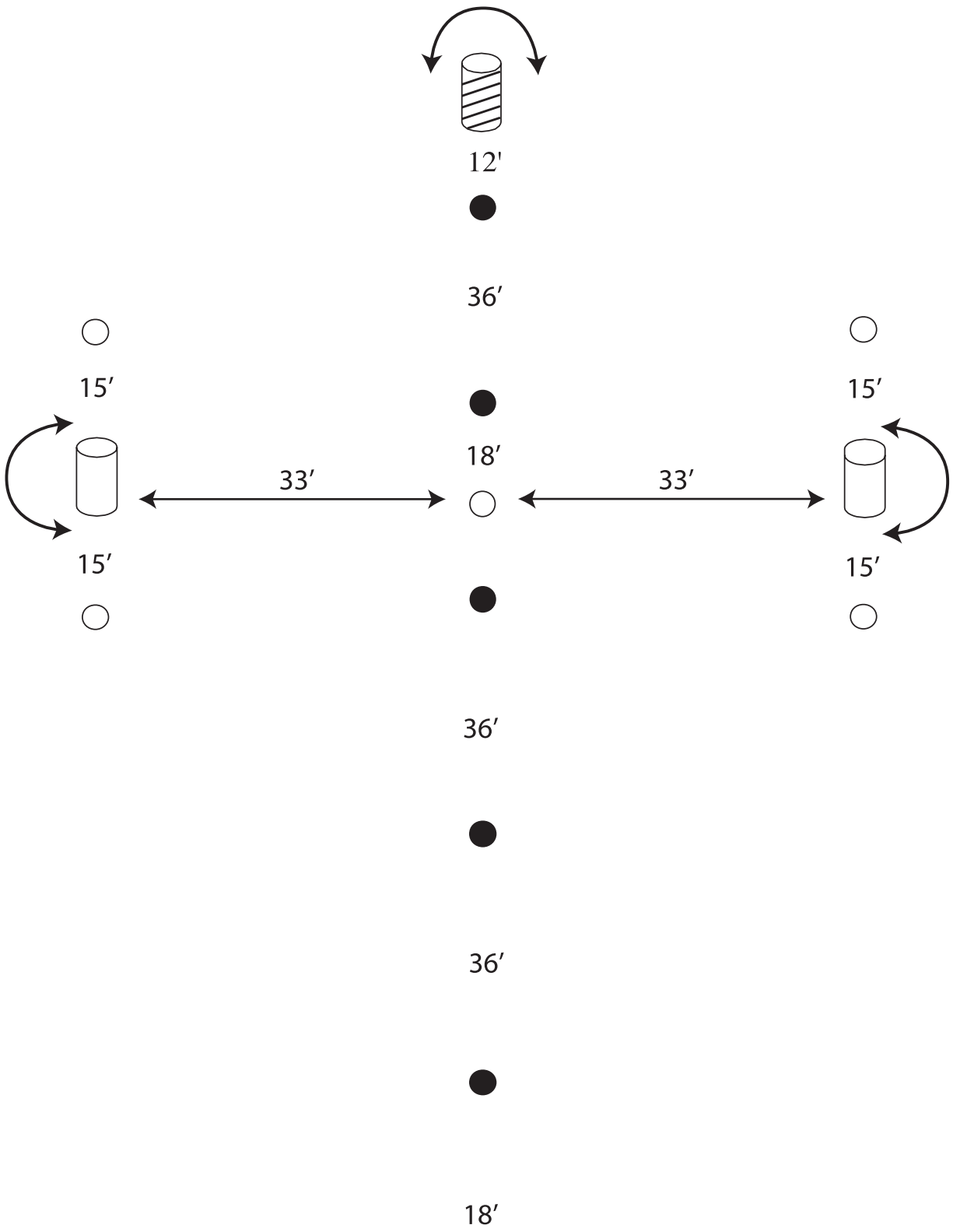

----- Timer

Course 12 - Certified

H. Engage the entire Random course first, then round the Rundown barrel.

Procedurals: 2, 3

Rifle/Shotgun Course

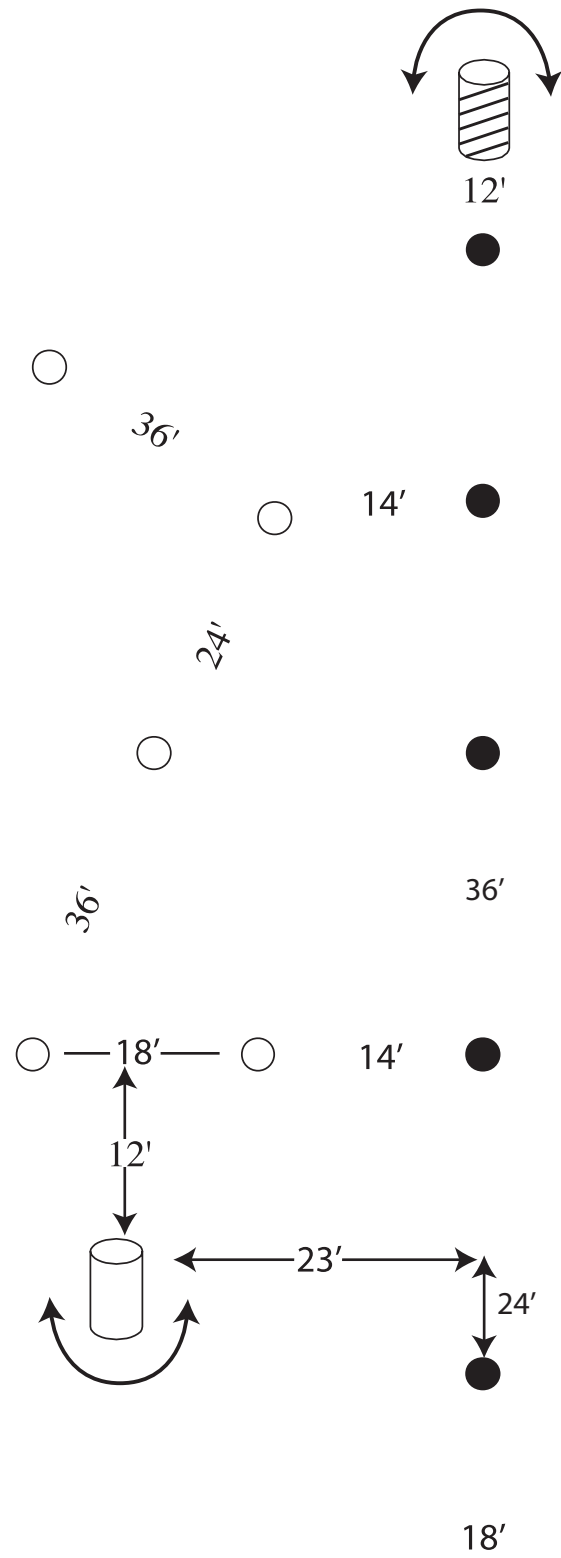

Start/Finish #13

B. Engage the entire Random course first, then round the Random barrel
 Procedurals: 2, 3

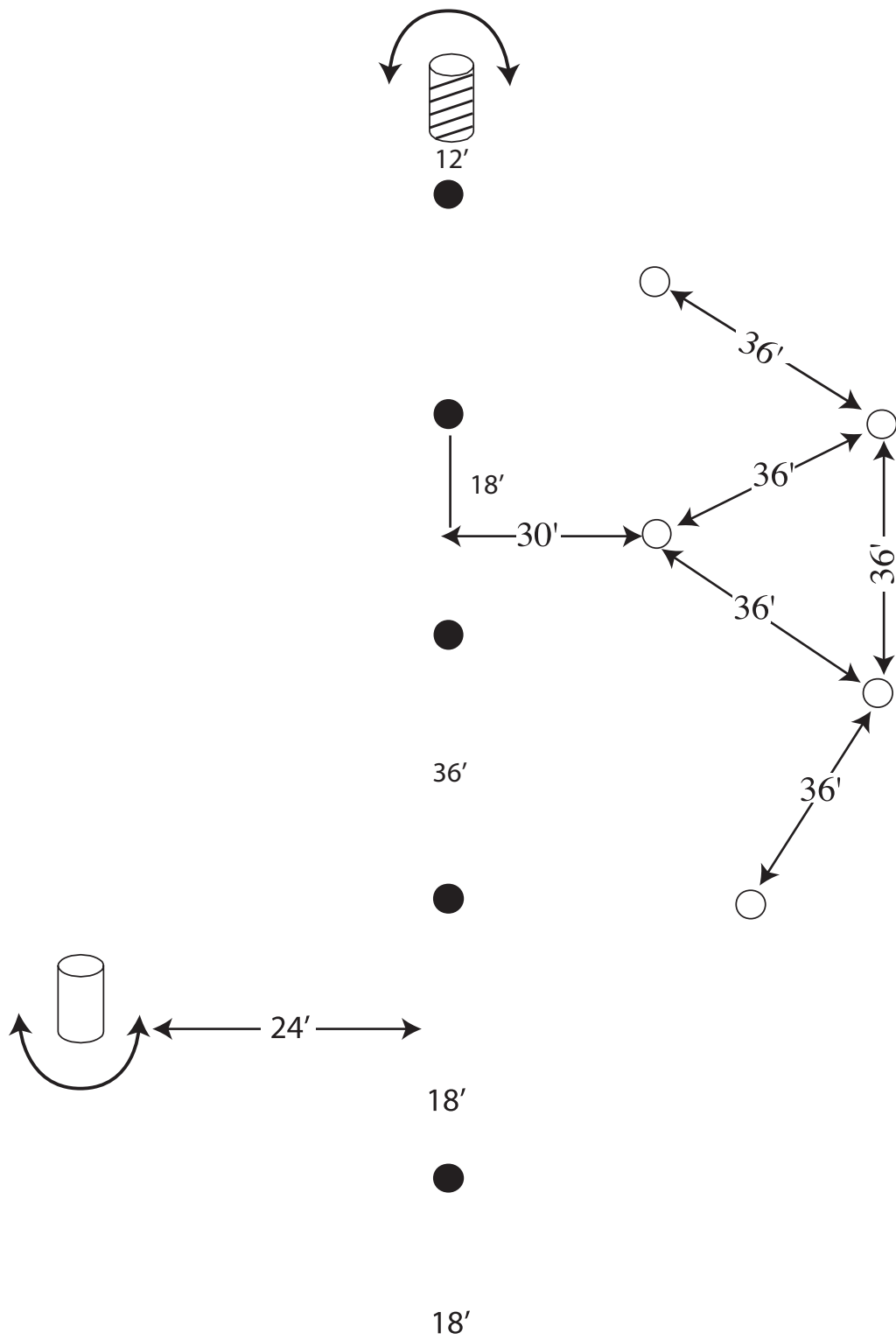

Start/Finish #14

B. Engage the entire Random course first, then round the Random barrel
 Procedurals: 2, 3

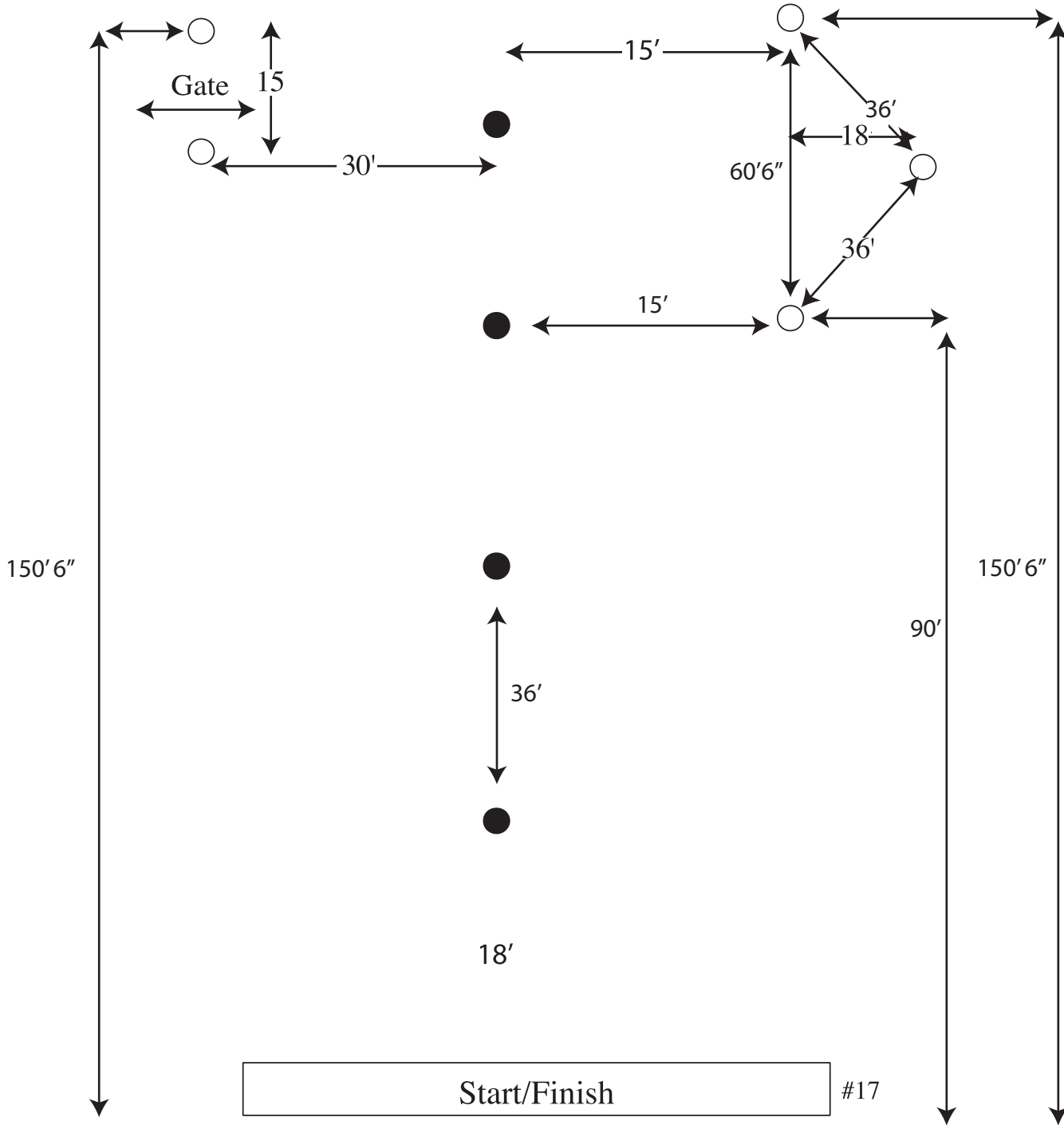
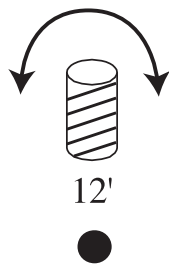

E. Engage all light targets first, then round the Rundown barrel.
 Procedurals: 2, 3

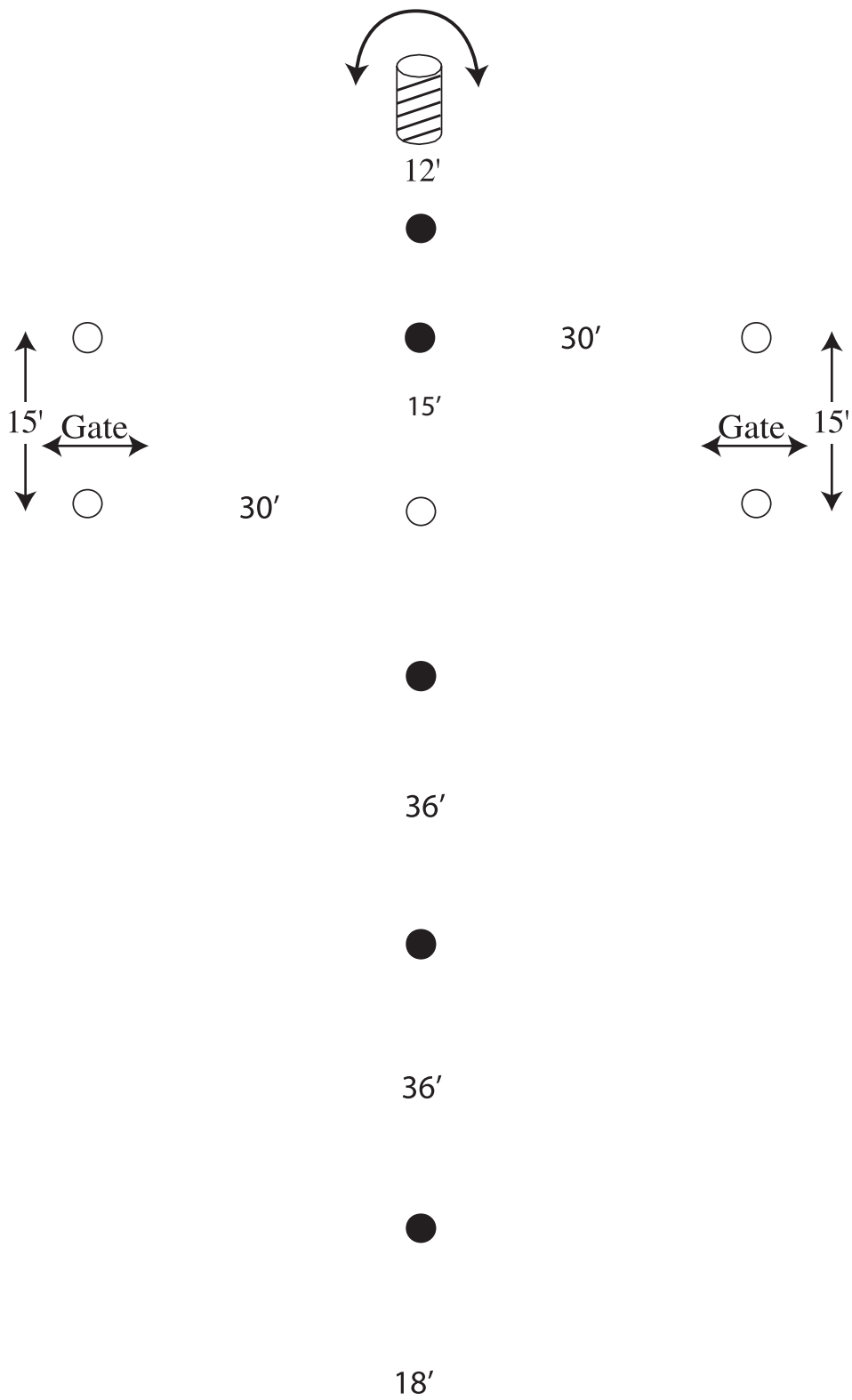

----- Timer

Course 18 - Certified

E. Engage all light targets first, then round the Rundown barrel.
 Procedurals: 2, 3
 Rifle/Shotgun Course

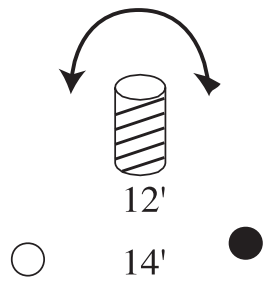

36'



18'

Start/Finish

#19

C. Engage 5 of one color, round the barrel(s), engage 5 of the other color
 Procedurals: 2, 3

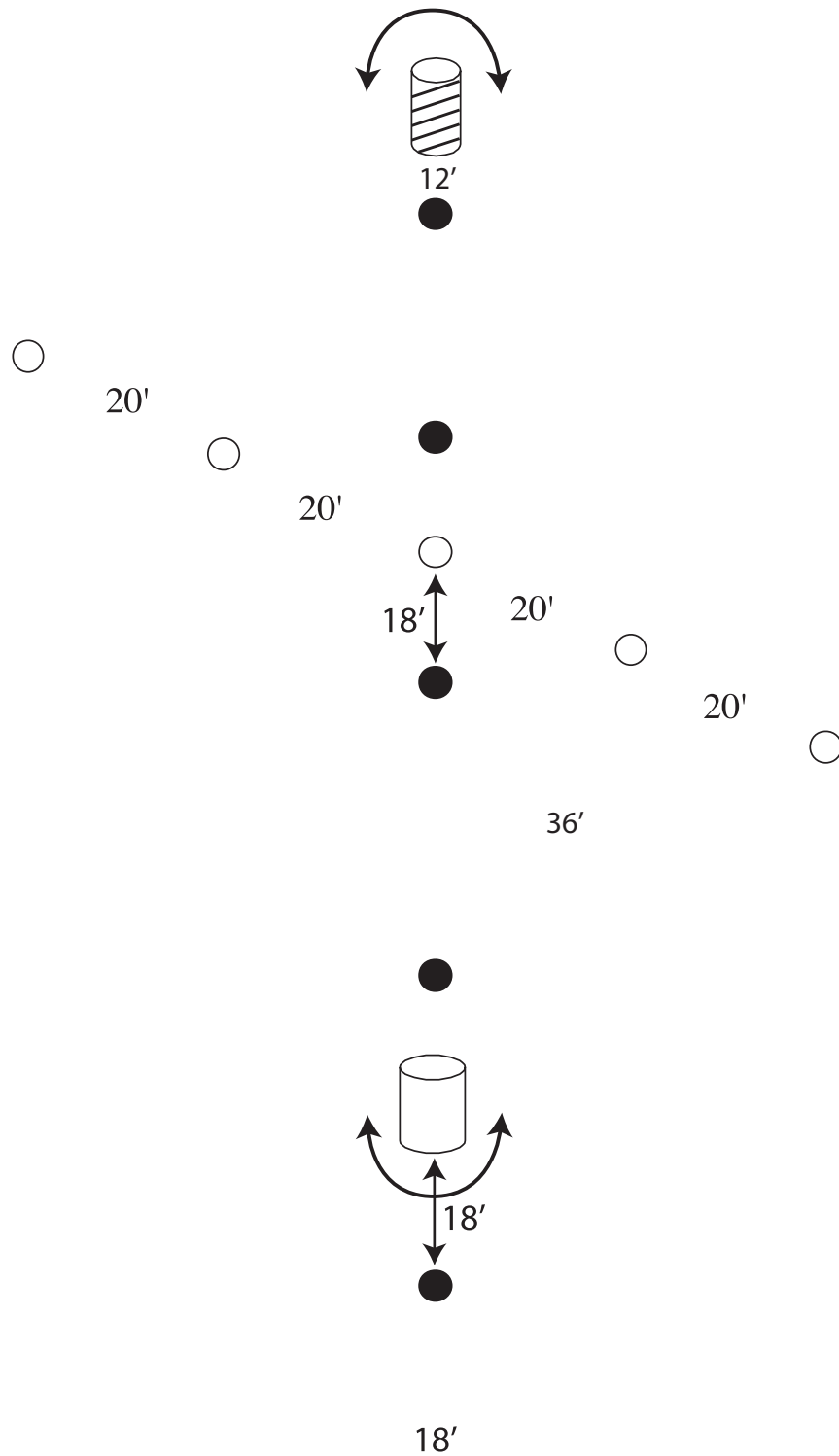

Start/Finish #20

B. Engage the entire Random course first, then round the Random barrel
 Procedurals: 2, 3
 Rifle/Shotgun Course

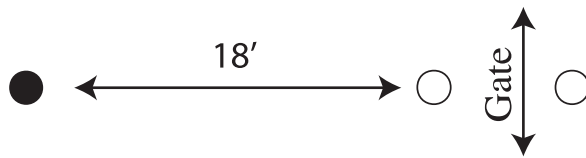
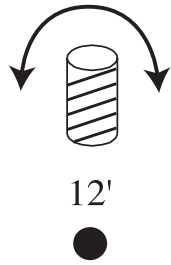

36'

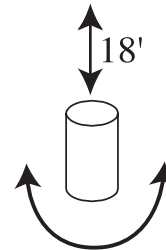

18'

Start/Finish #21

B. Engage the entire Random course first, then round the Random barrel
 Procedurals: 2, 3

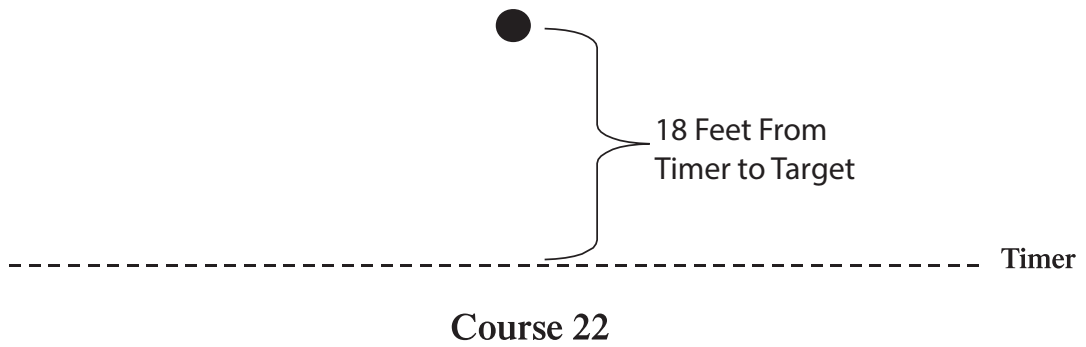
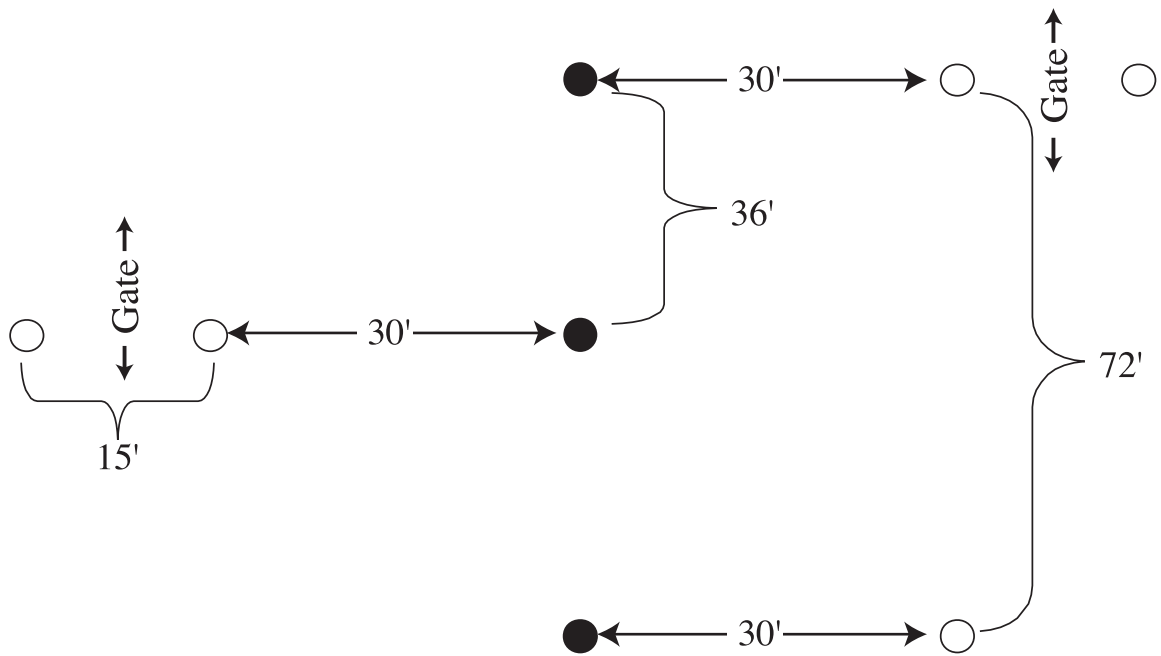
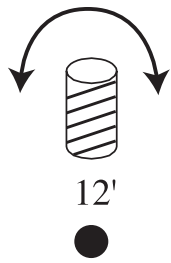

E. Engage all light targets first, then round the Rundown barrel.
 Procedurals: 2, 3

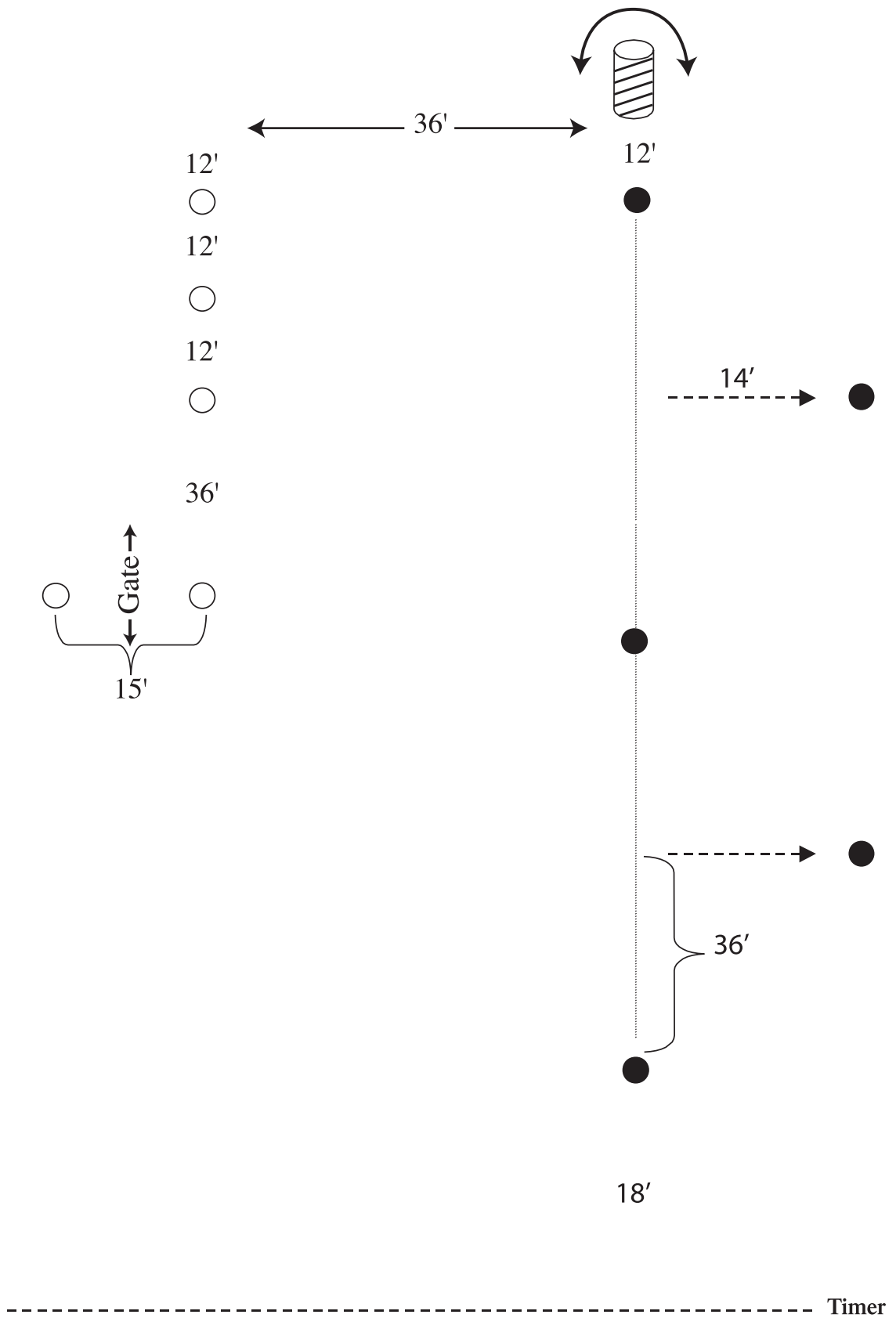

Course 23 - Certified

E. Engage all light targets first, then round the Rundown barrel.
 Procedurals: 2, 3

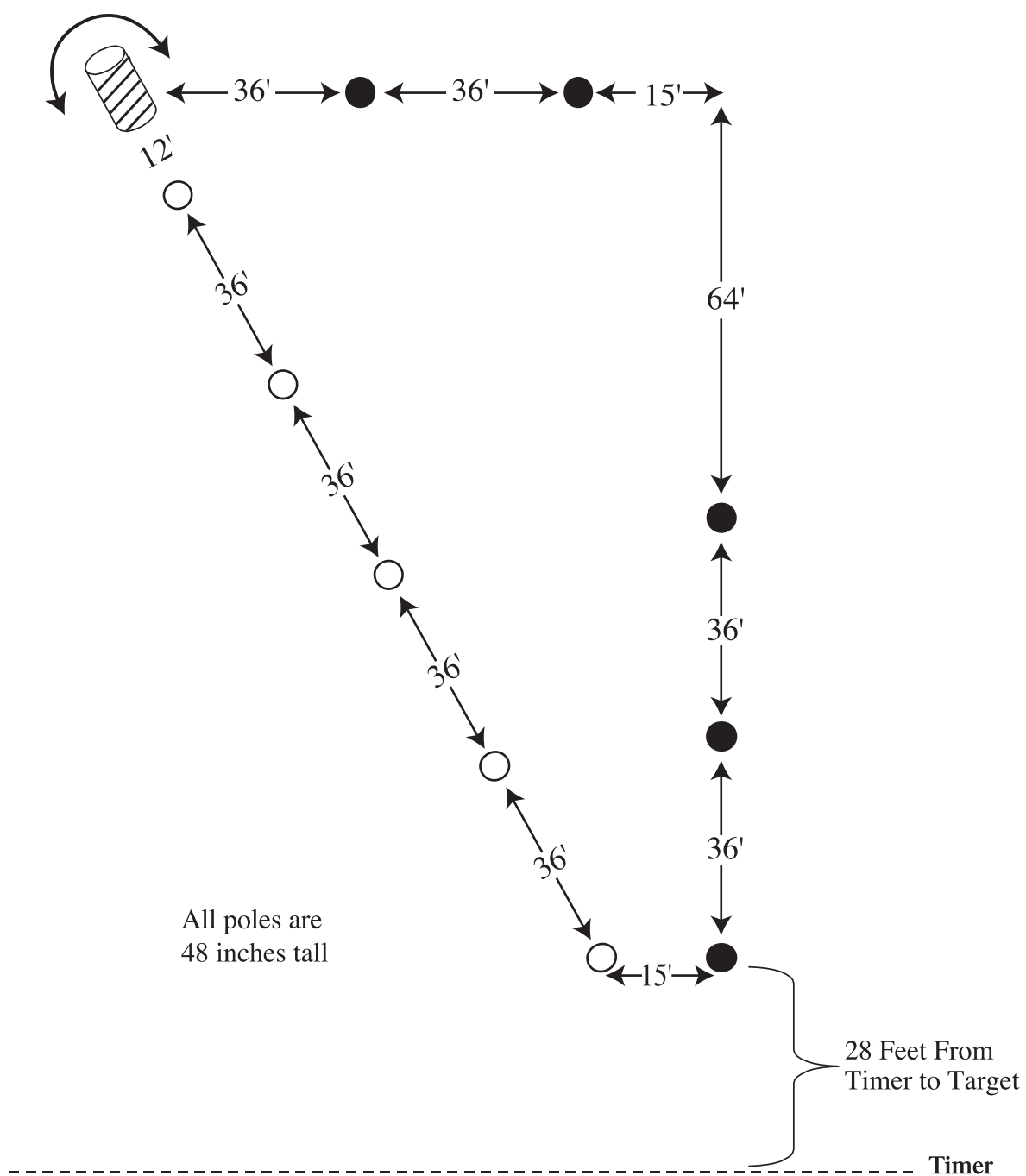

Course 24 - Certified

C. Engage 5 of one color, round the barrel(s), engage 5 of the other color
 Procedurals: 2, 3

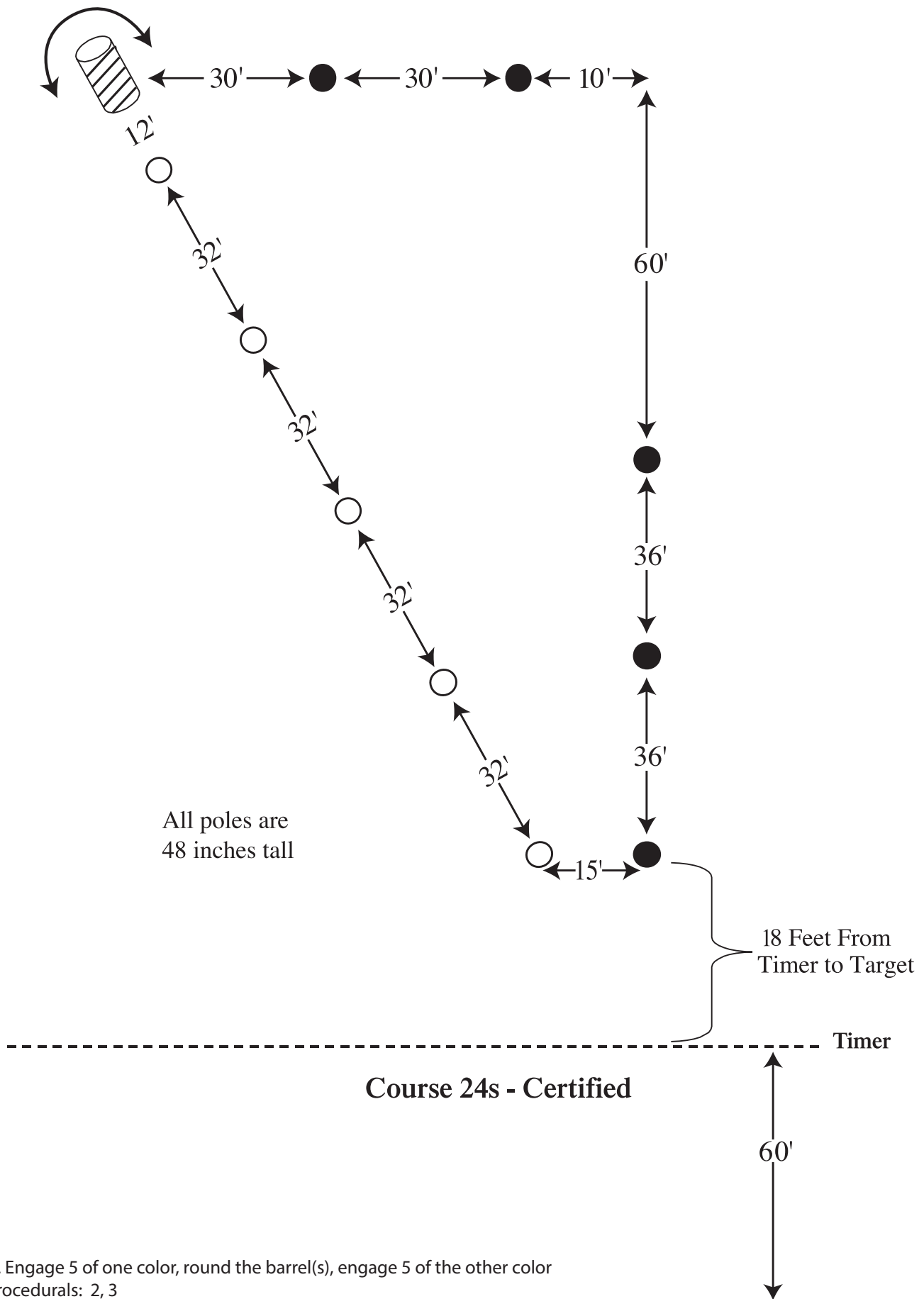

C. Engage 5 of one color, round the barrel(s), engage 5 of the other color
 Procedurals: 2, 3

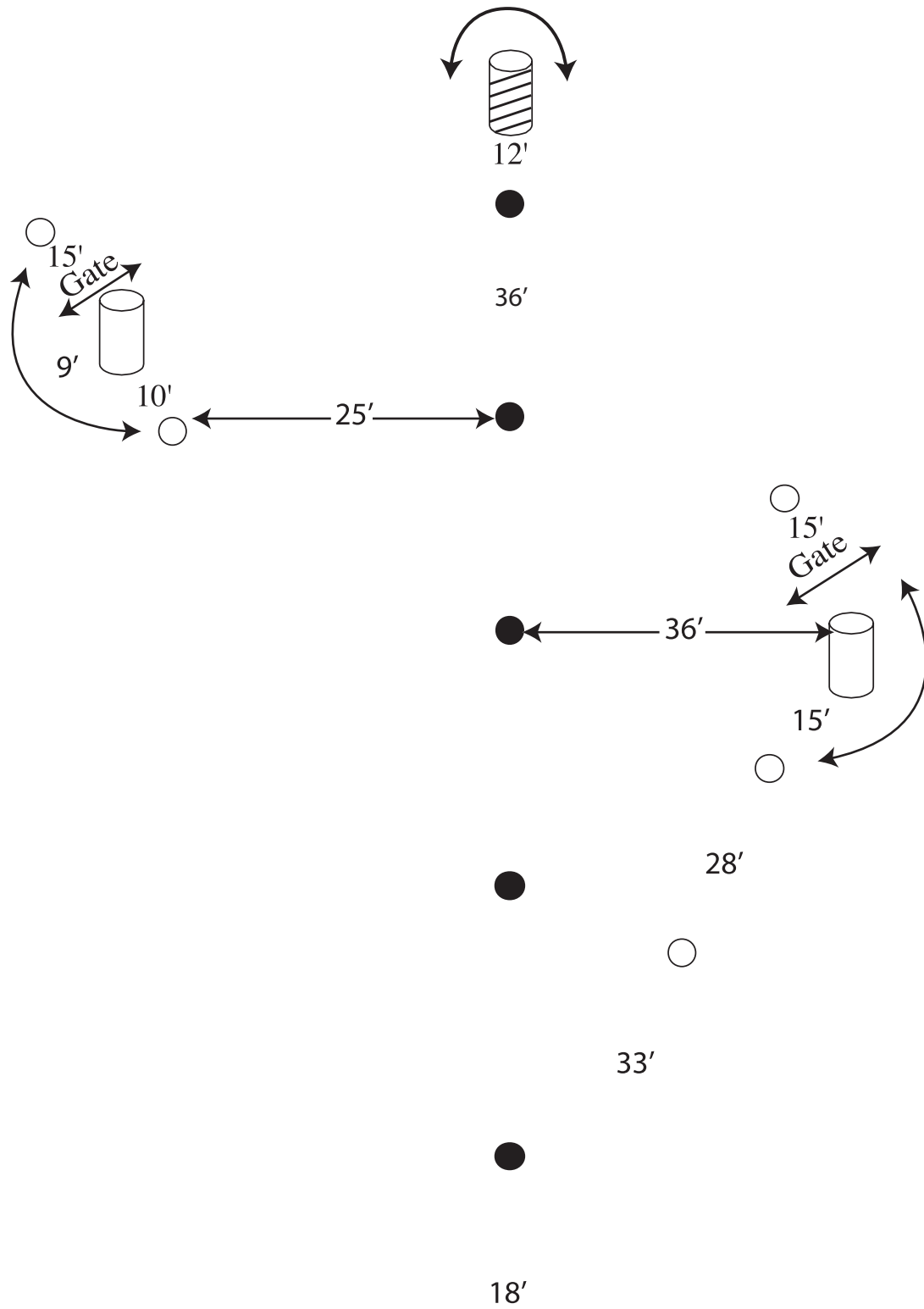

Start/Finish

#25

H. Engage the entire Random course first, then round the Rundown barrel.
 Procedurals: 2, 3

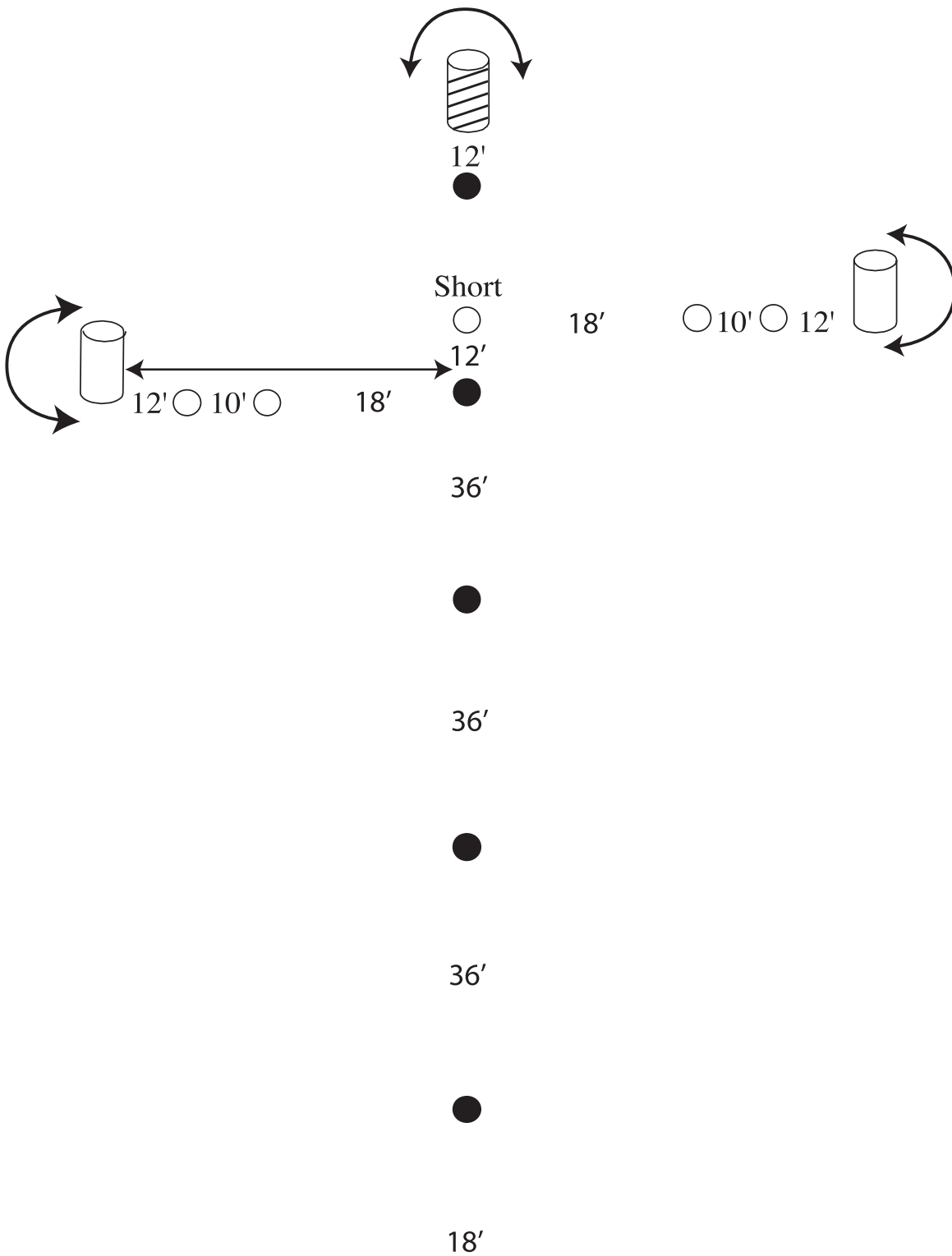

----- Timer

Course 26 - Certified

H. Engage the entire Random course first, then round the Rundown barrel.
 Procedurals: 2, 3

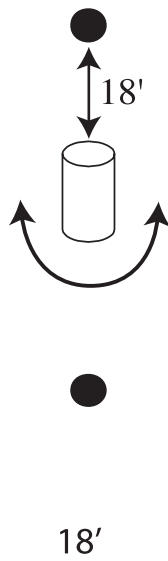
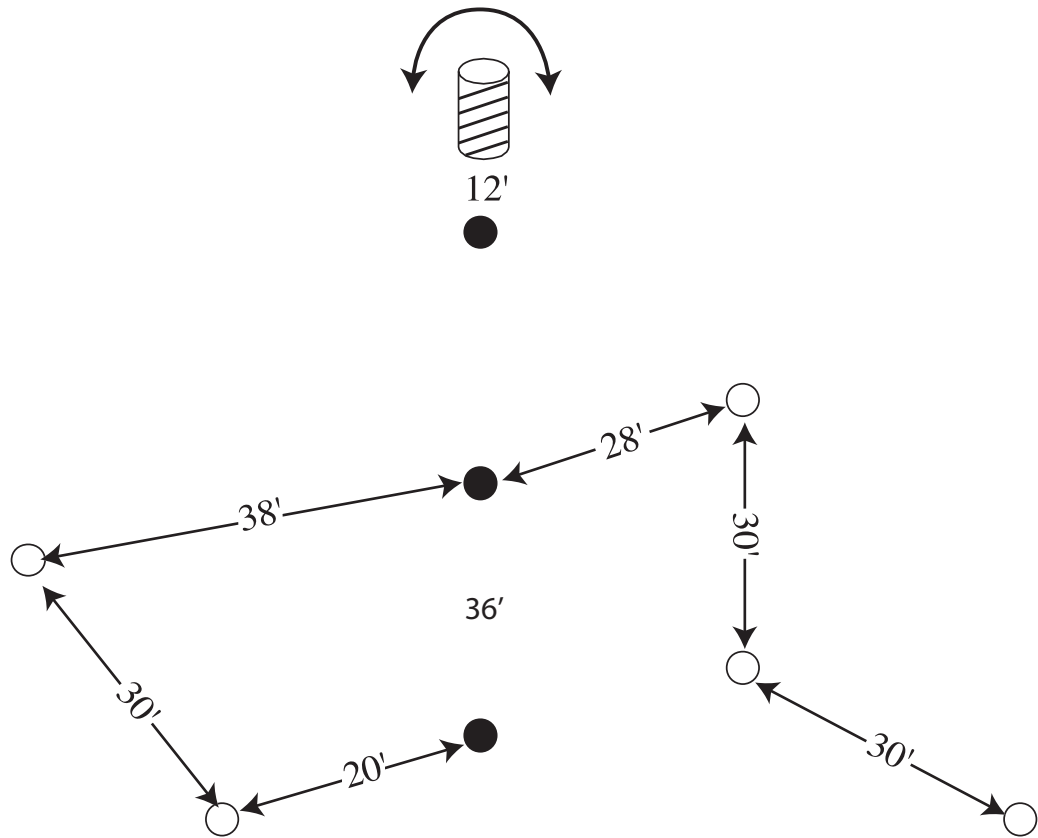

Start/Finish #27

B. Engage the entire Random course first, then round the Random barrel
 Procedurals: 2, 3
 Rifle/Shotgun Course

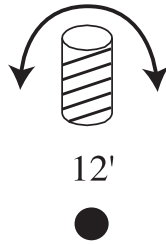

Engage Target on Barrel Last.

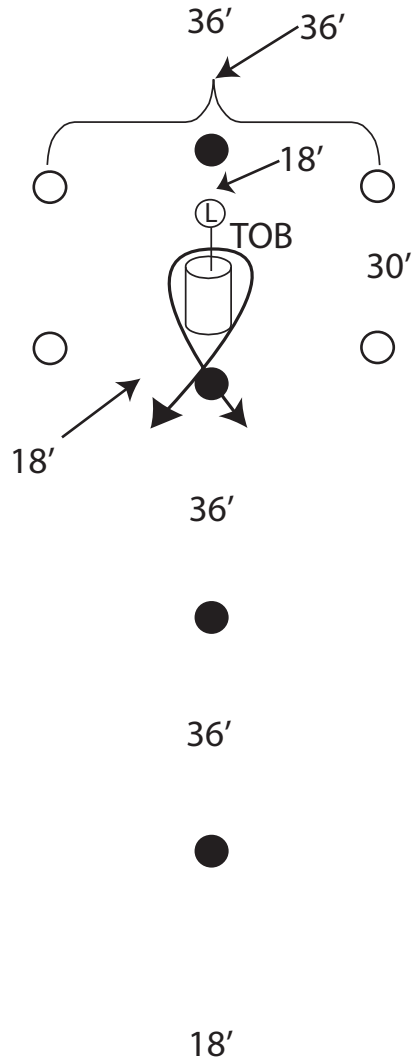

----- Timer

Course 28 - Certified

B. Engage the entire Random course first, then round the Random barrel
 Procedurals: 1, 3
 Rifle/Shotgun Course

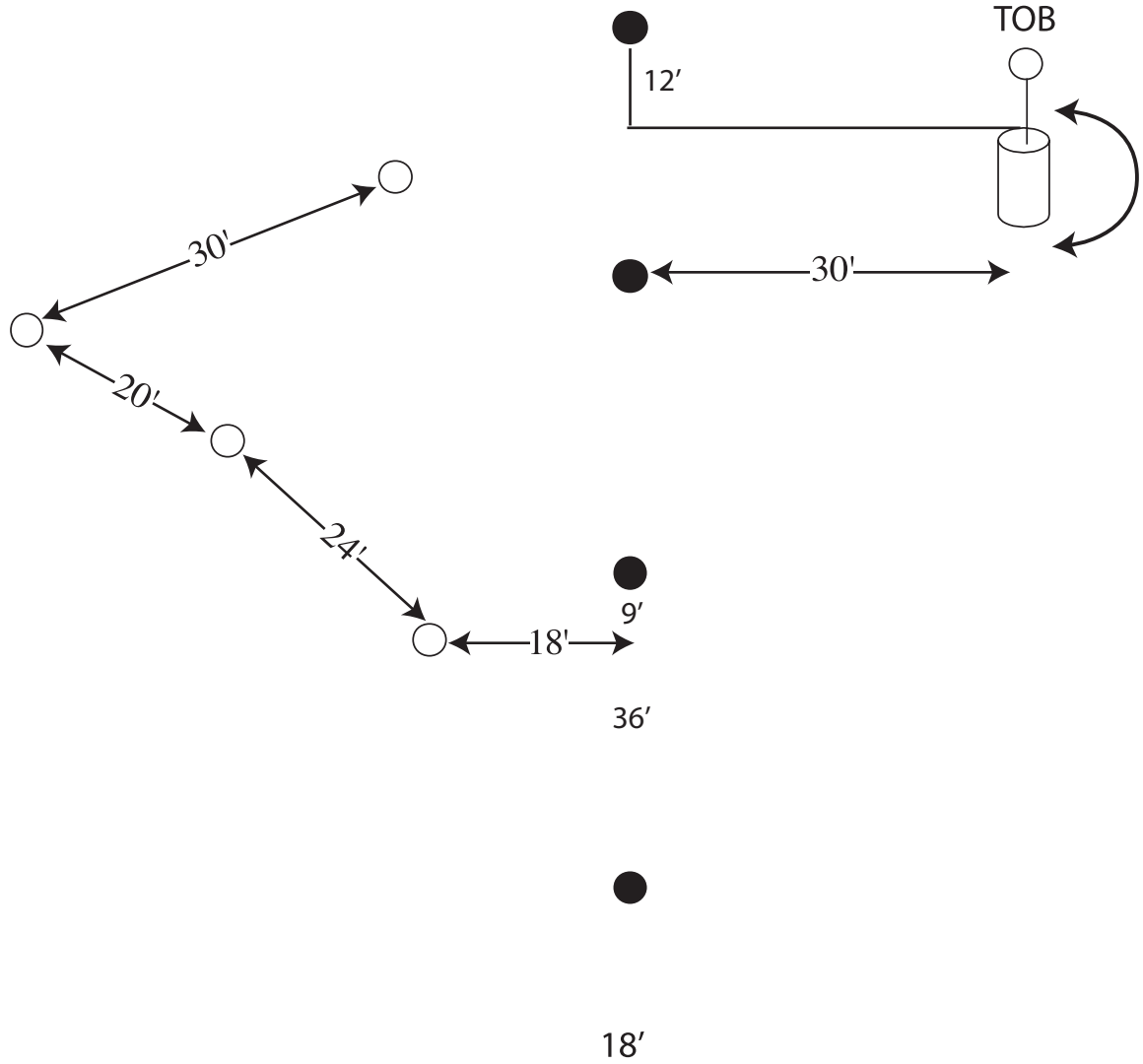
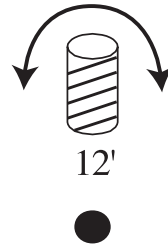

Start/Finish

 #29

B. Engage the entire Random course first, then round the Random barrel
 Procedurals: 2, 3

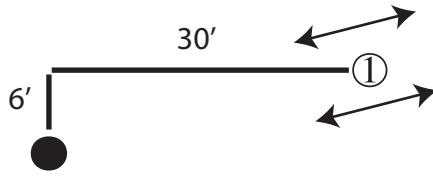
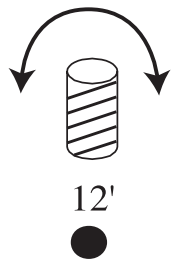

36'

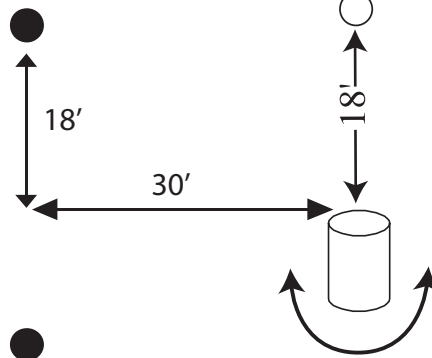
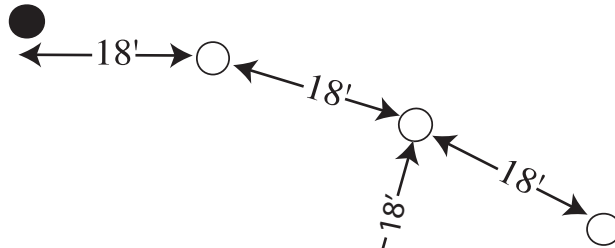

18'

Start/Finish

#31

- A. Engage the farthest light targets first
 - B. Engage the entire Random course first, then round the Random barrel
- Procedurals: 1, 2, 3

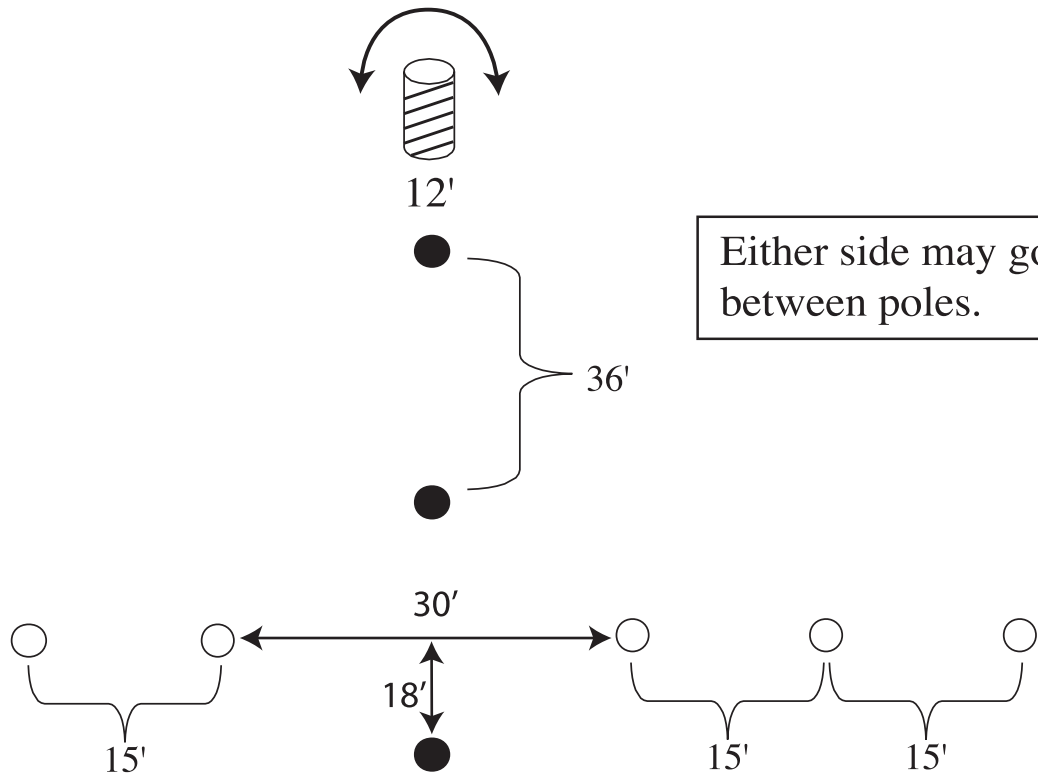

Either side may go between poles.

All poles are 48 inches tall

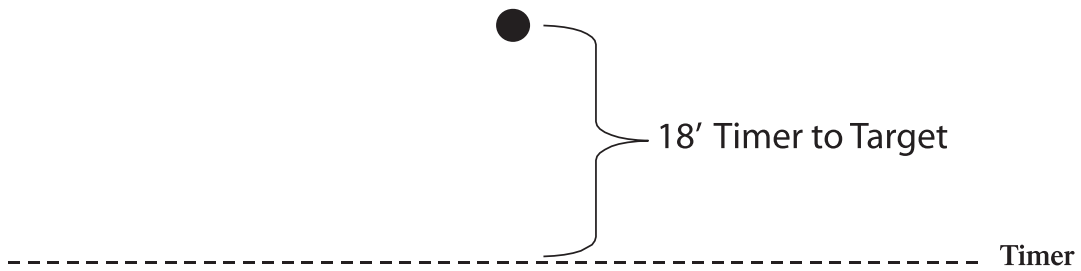

Course 32 - Certified

E. Engage all light targets first, then round the Rundown barrel.
 Procedurals: 2, 3

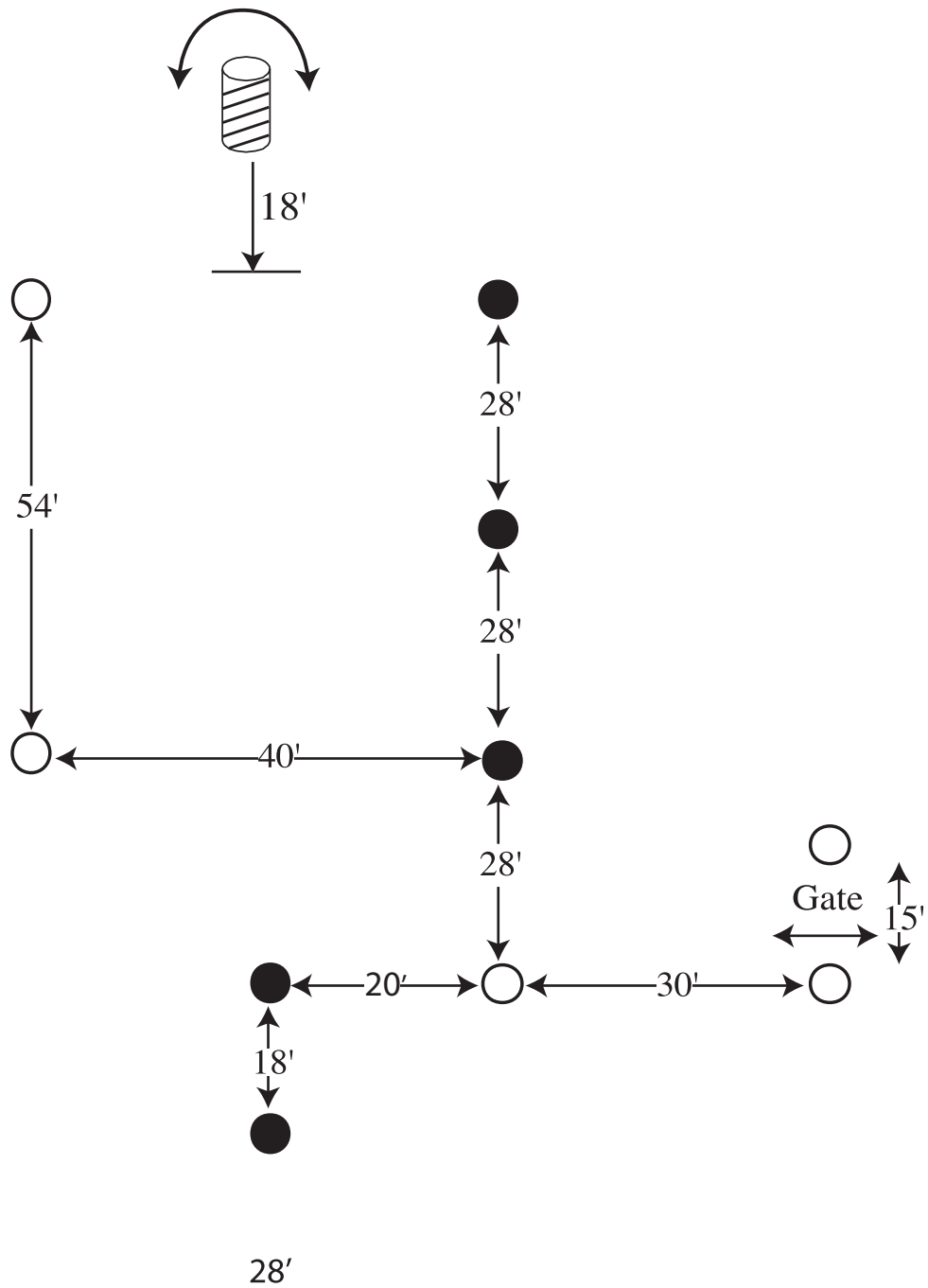

Start/Finish #34

E. Engage all light targets first, then round the Rundown barrel.
 Procedurals: 2, 3

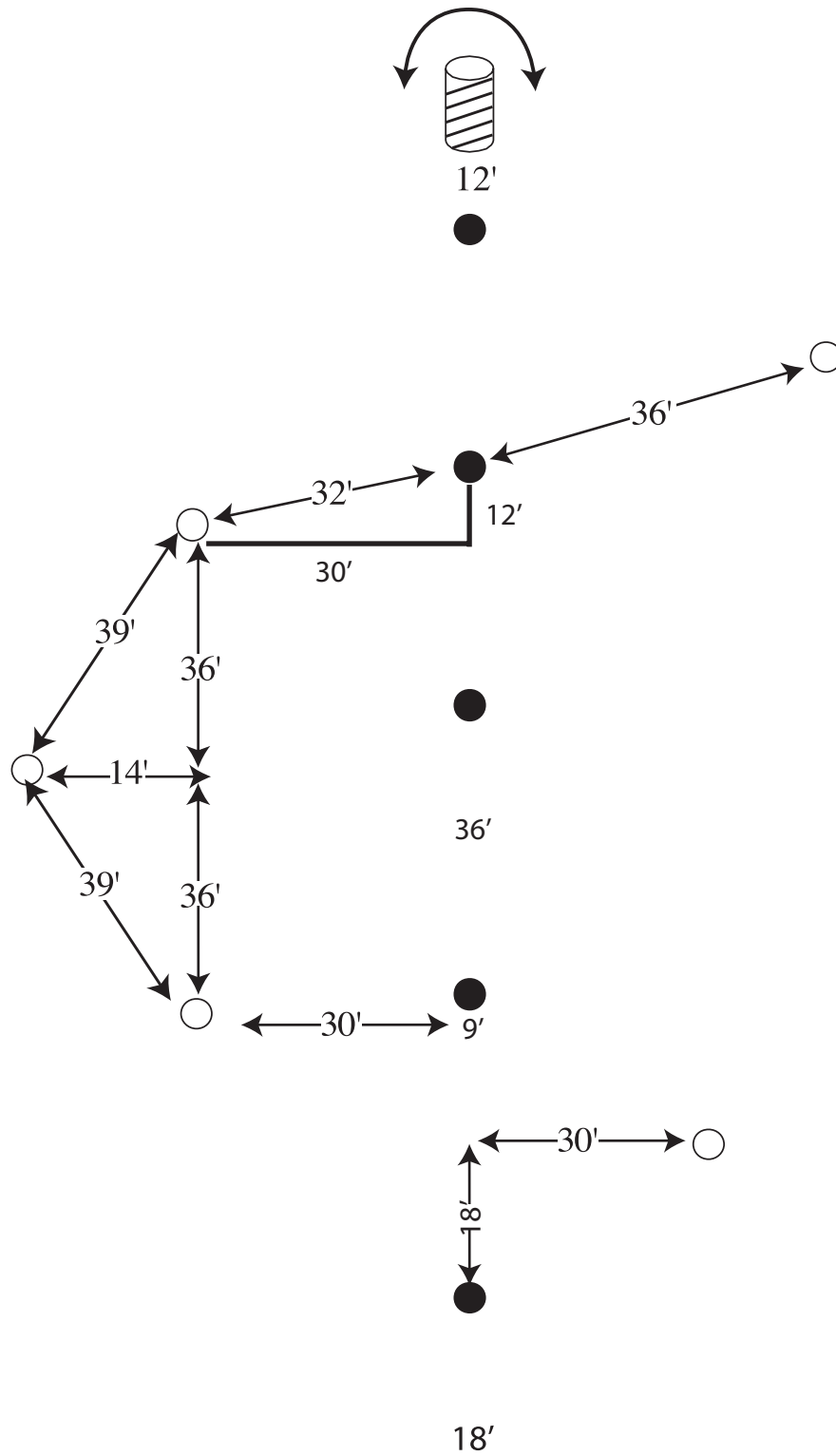

Start/Finish #35

E. Engage all light targets first, then round the Rundown barrel.
 Procedurals: 2, 3

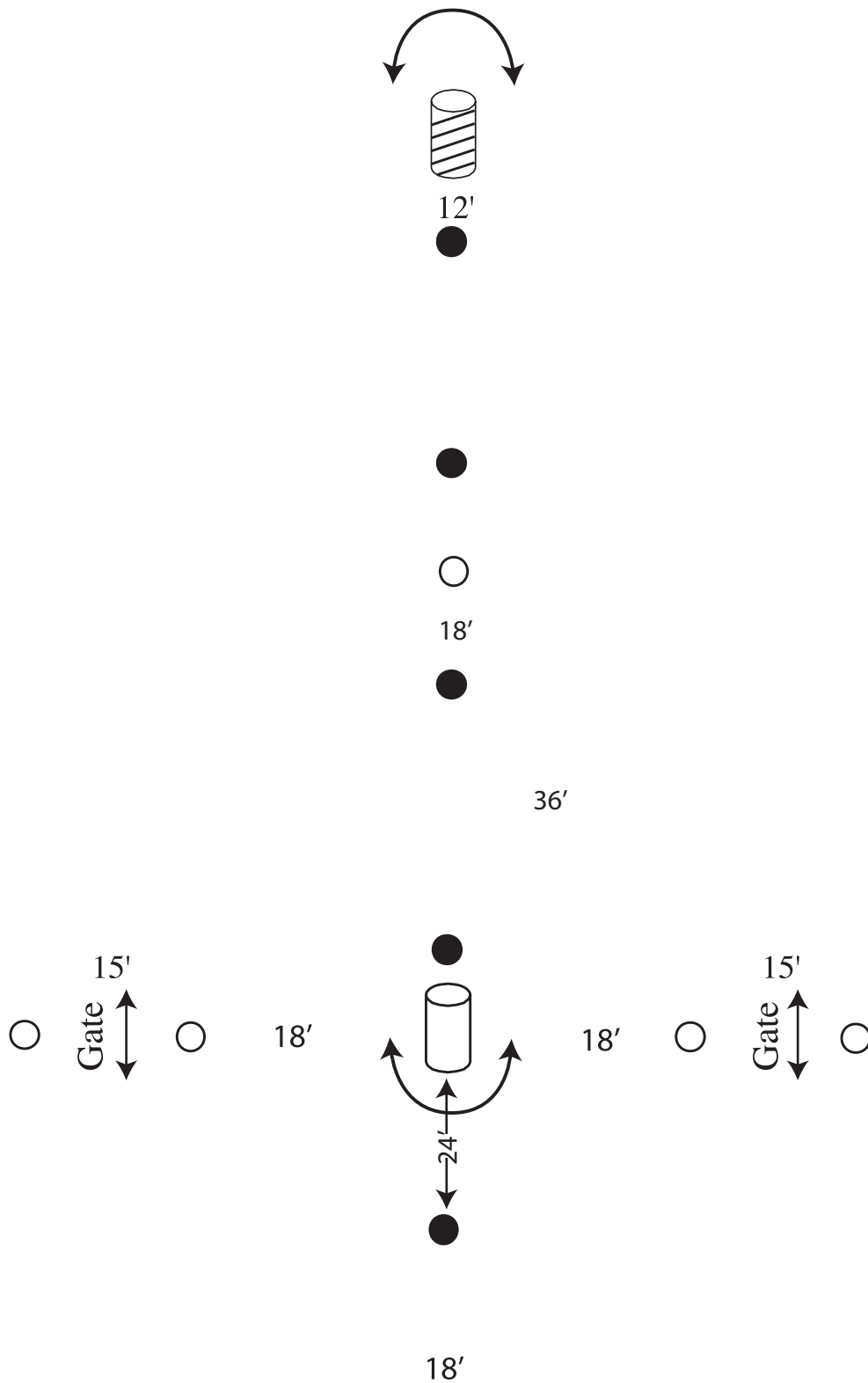

Start/Finish

 #36

B. Engage the entire Random course first, then round the Random barrel
 Procedurals: 2, 3
 Rifle/Shotgun Course

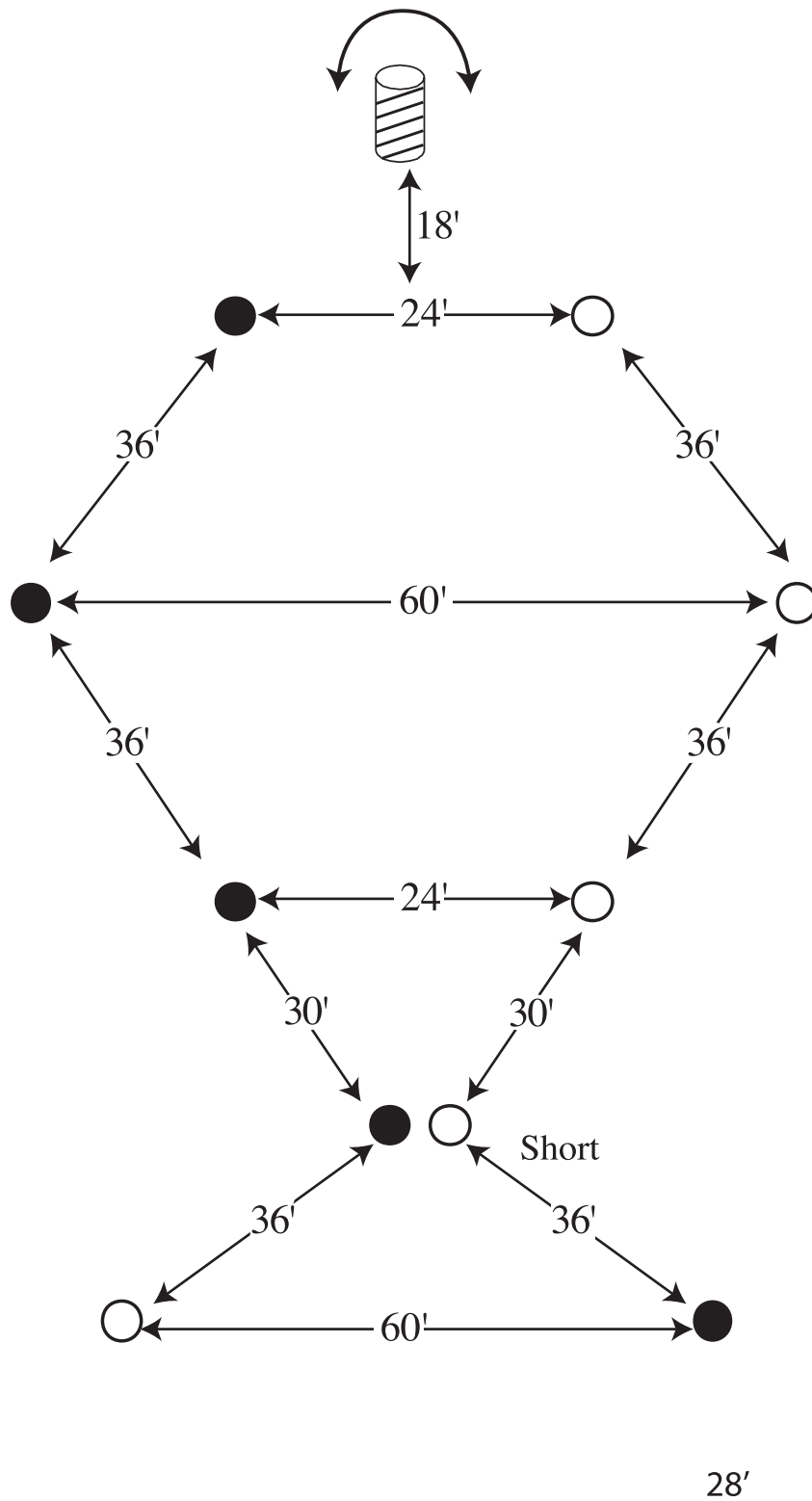

Start/Finish Line #37

C. Engage 5 of one color, round the barrel(s), engage 5 of the other color
 Procedurals: 2, 3

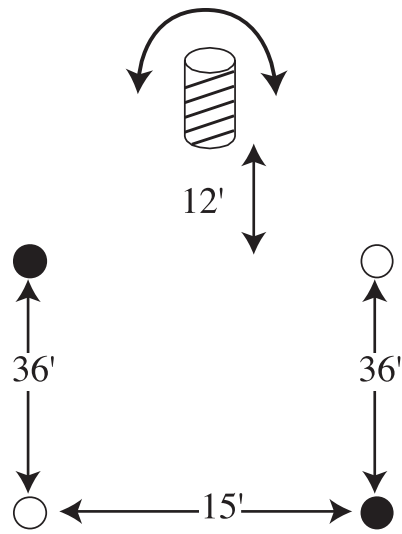

18'

Start/Finish

#40

C. Engage 5 of one color, round the barrel(s), engage 5 of the other color
 Procedurals: 2, 3

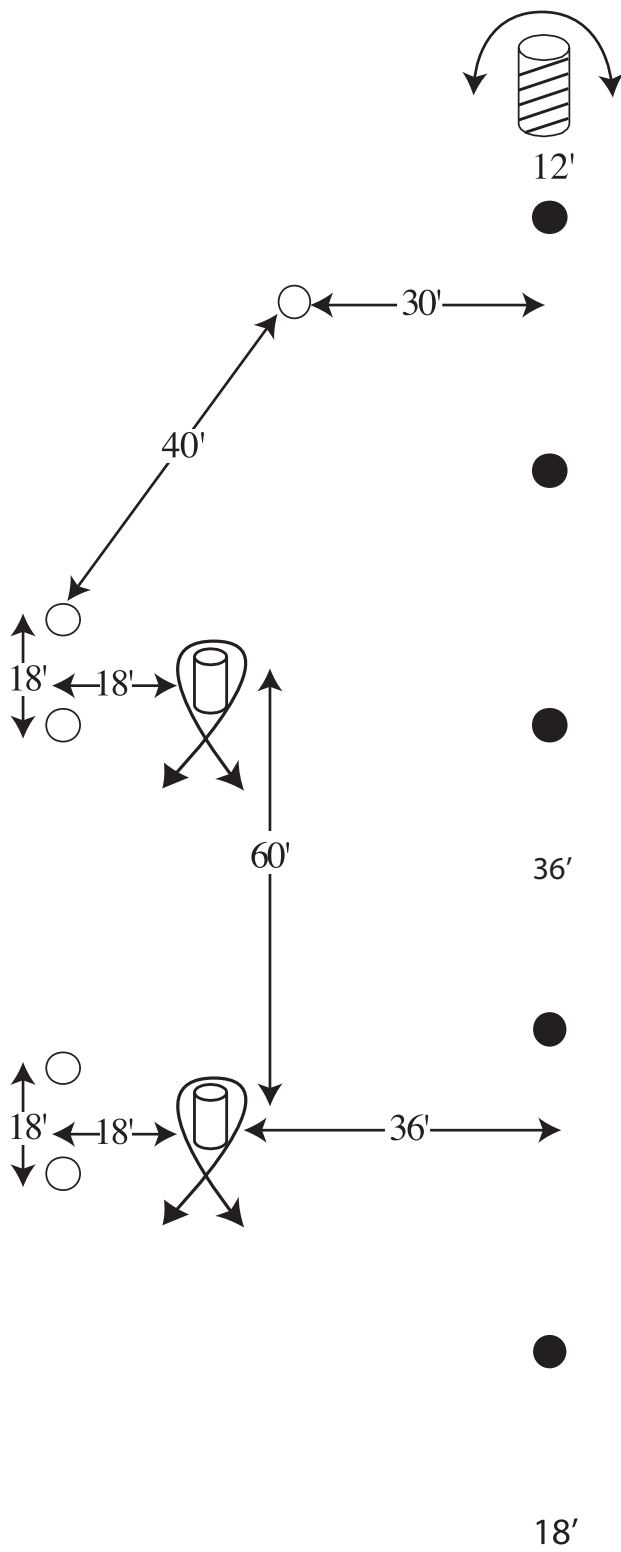

Start/Finish #41

H. Engage the entire Random course first, then round the Rundown barrel.
 Procedurals: 2, 3

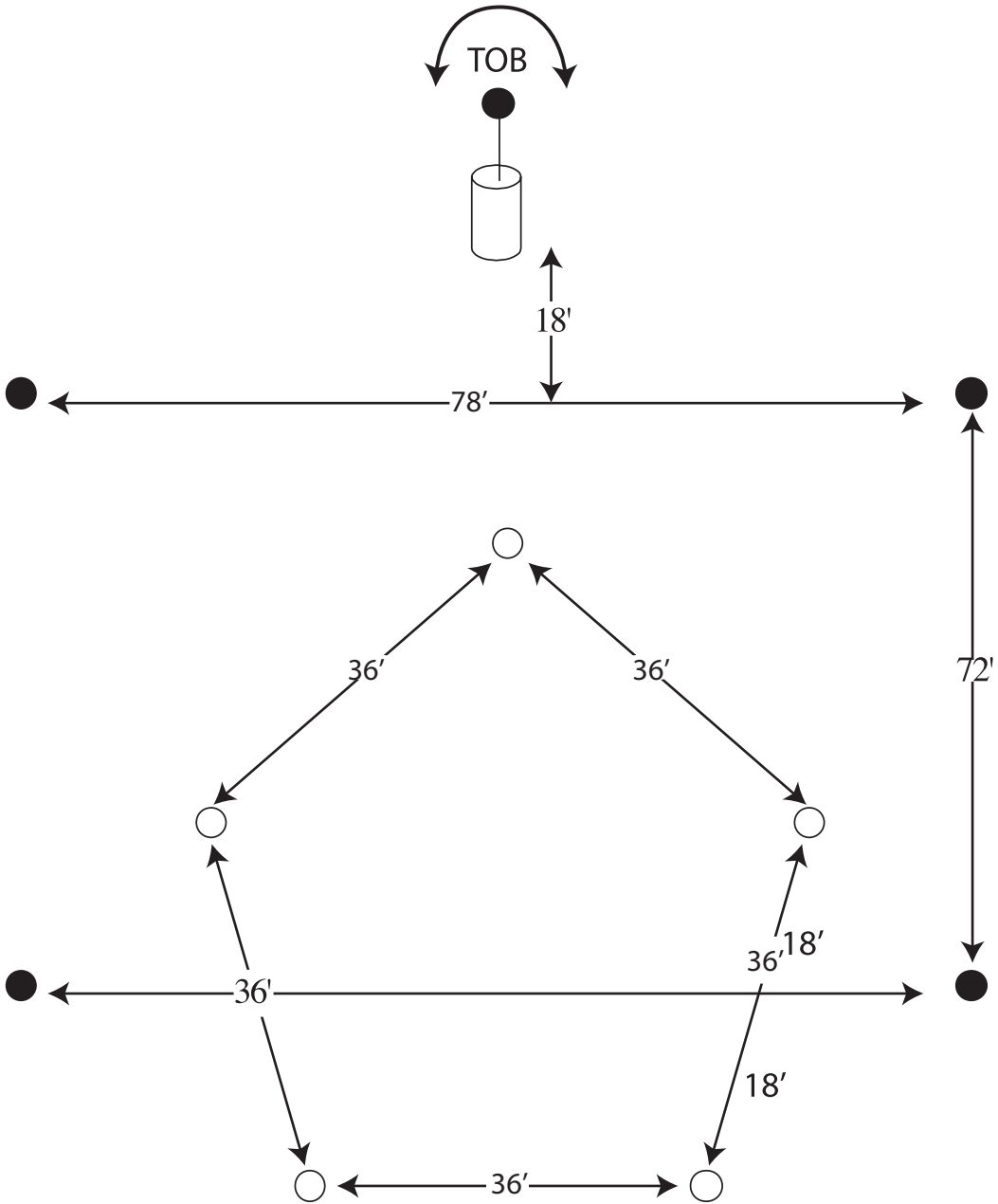

28'

Start/Finish

#42

G. Engage all the light targets first. Then engage the dark targets. You must round the barrel.
 Procedurals: 1

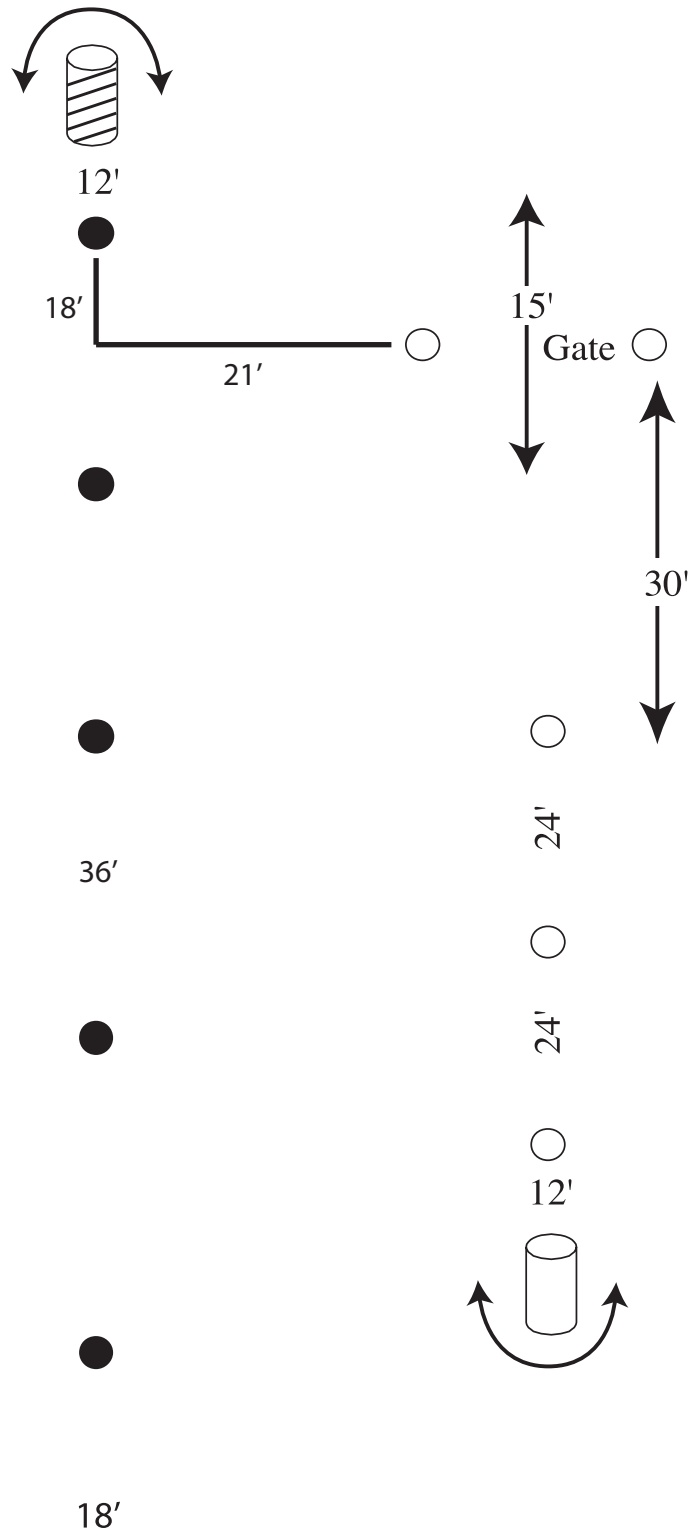

Start/Finish

#43

B. Engage the entire Random course first, then round the Random barrel
 Procedurals: 2, 3

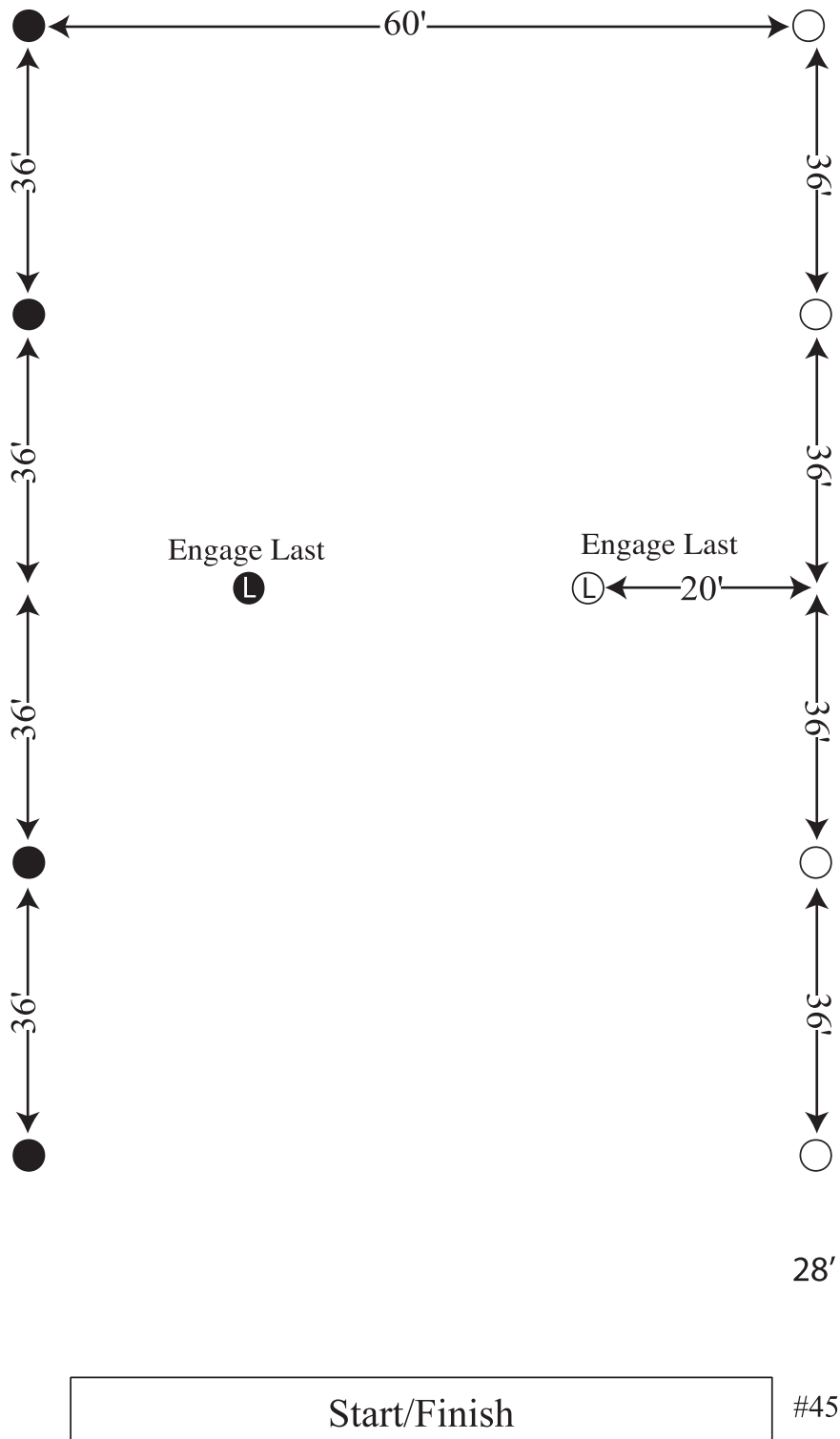

F. Engage 5 of one color, then engage 5 of the other color.
 Procedurals: 1

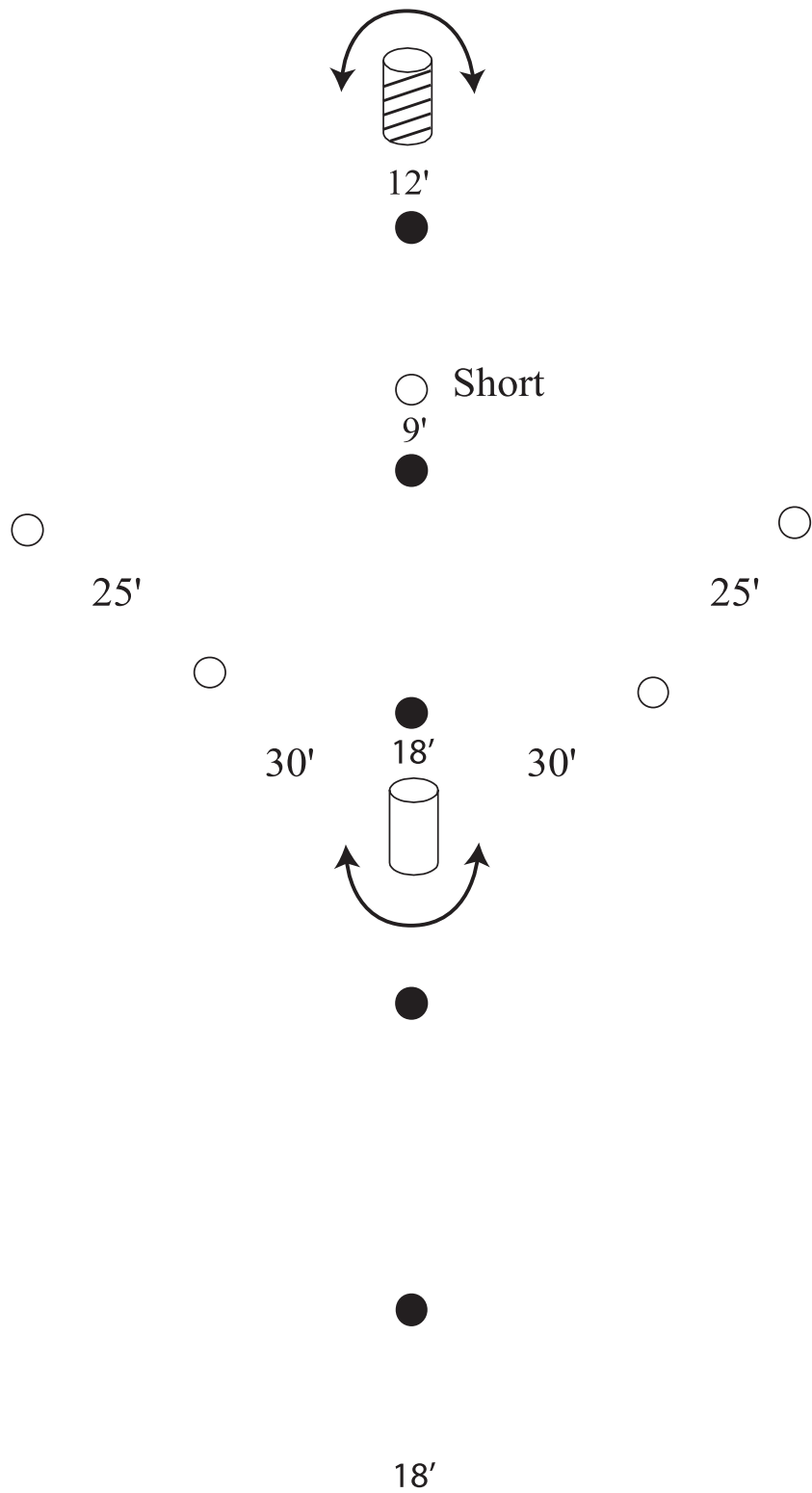

Start/Finish #47

B. Engage the entire Random course first, then round the Random barrel
 Procedurals: 2, 3
 Rifle/Shotgun Course

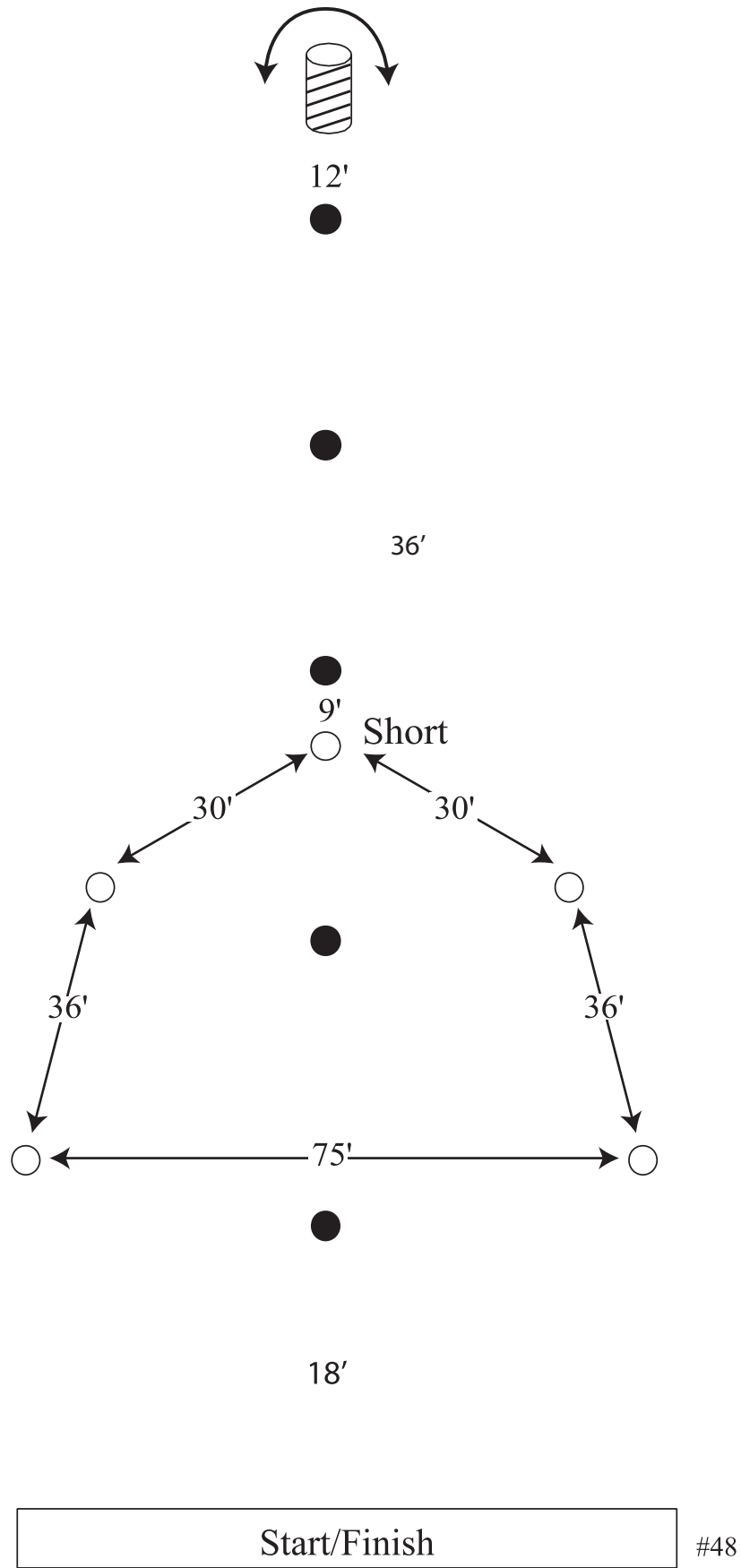

E. Engage all light targets first, then round the Rundown barrel.
 Procedurals: 2, 3
 Rifle/Shotgun Course

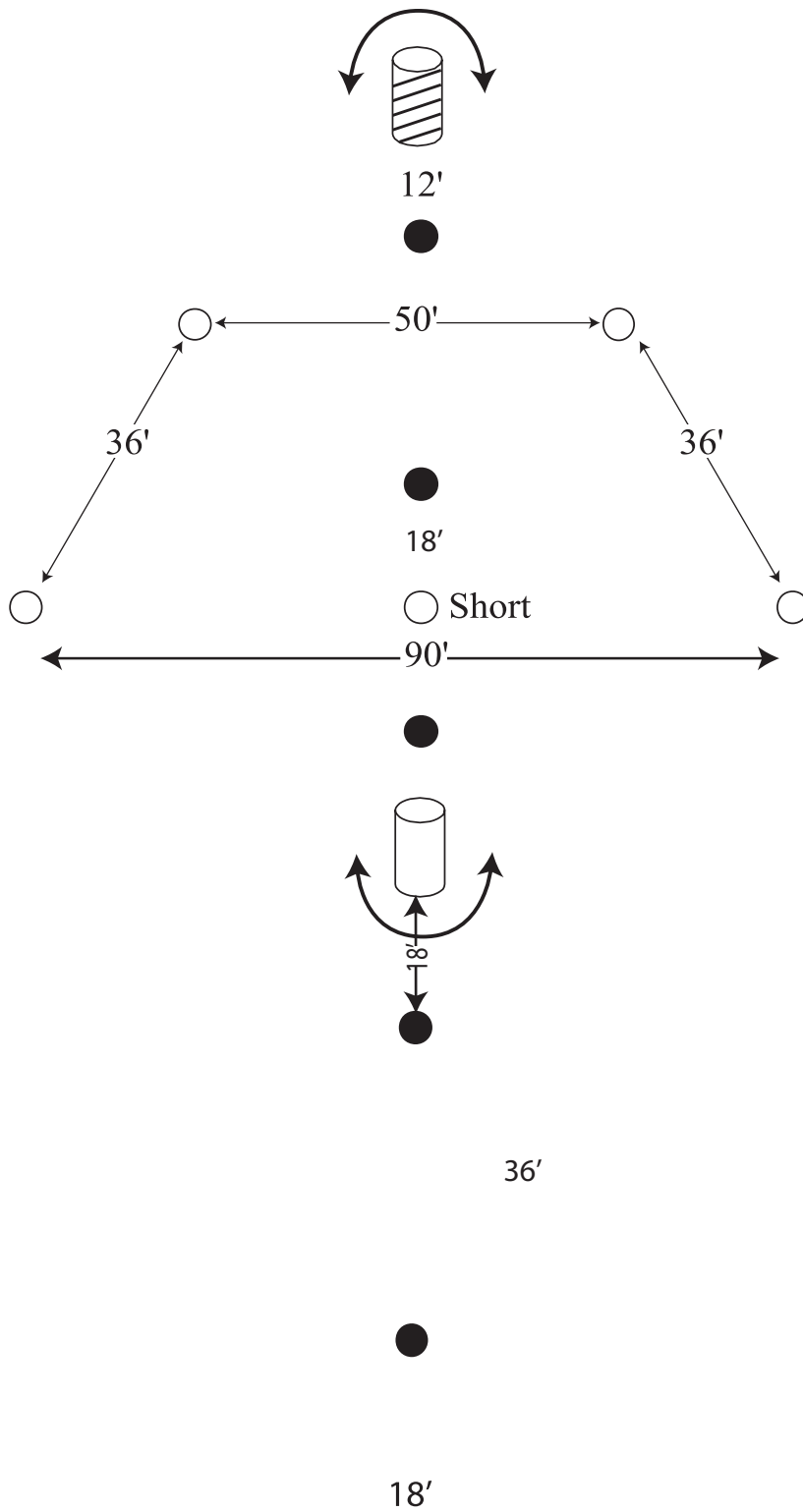

Start/Finish

#49

B. Engage the entire Random course first, then round the Random barrel
 Procedurals: 2, 3
 Rifle/Shotgun Course

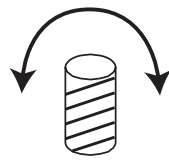

12'



36'

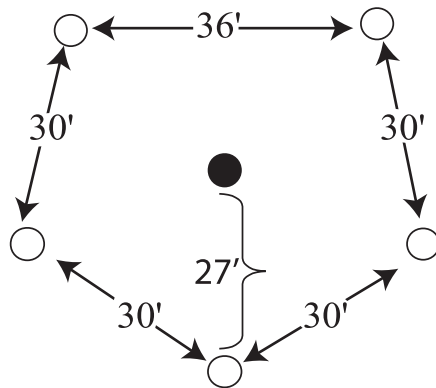

9' Short



36'



18'

----- Timer

Course 50 - Certified

E. Engage all light targets first, then round the Rundown barrel.

Procedurals: 2, 3

Rifle/Shotgun Course

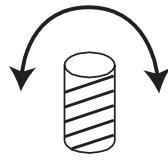

12'



33'

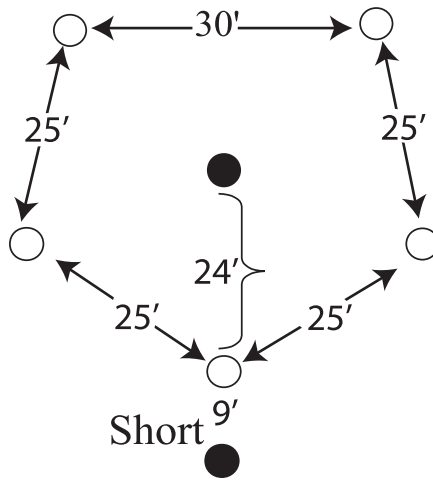

33'



9'

----- Timer

Course 50s - Certified

E. Engage all light targets first, then round the Rundown barrel.

Procedurals: 2, 3

Rifle/Shotgun Course

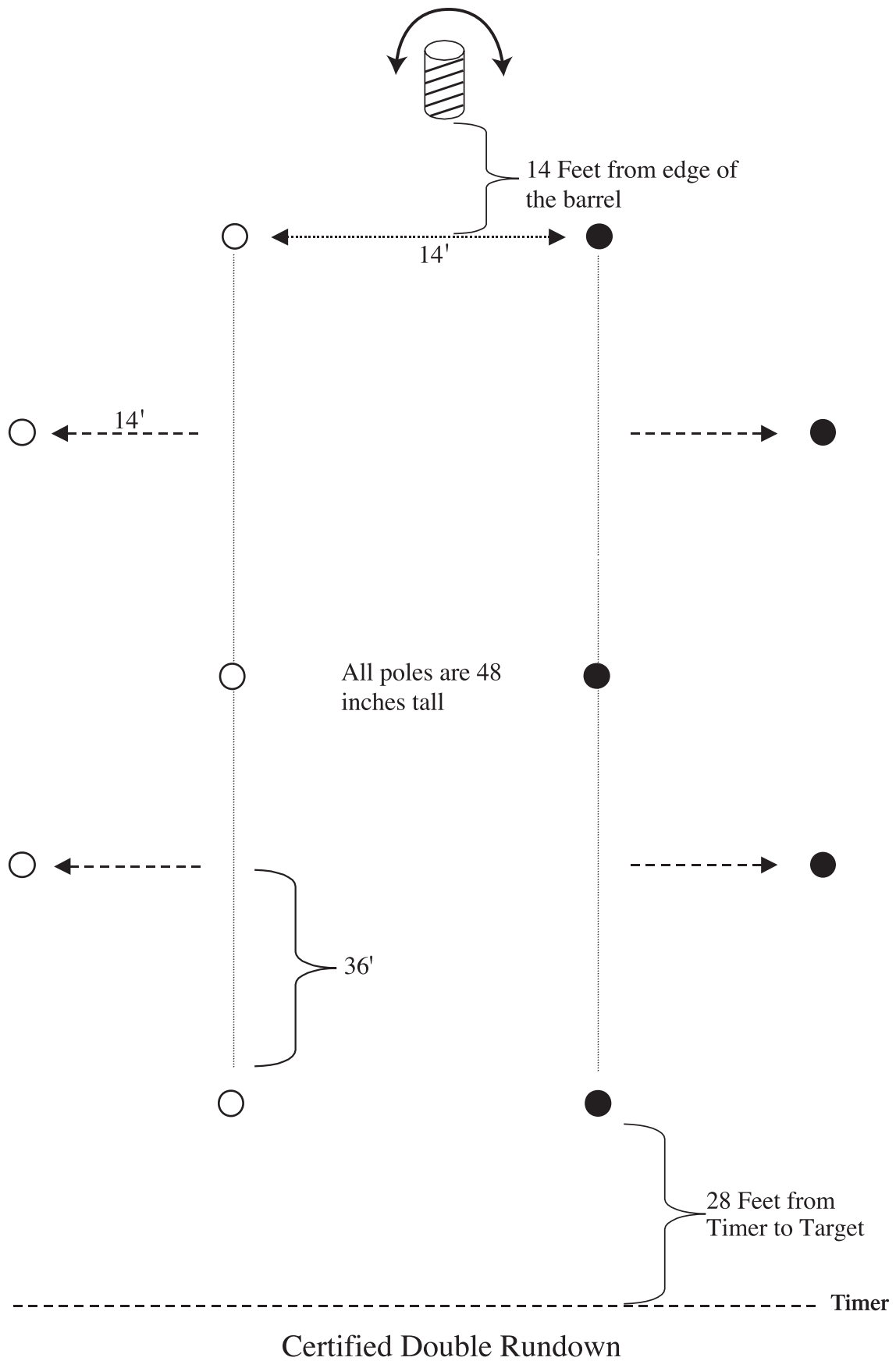

C. Engage 5 of one color, round the barrel(s), engage 5 of the other color
 Procedurals: 2, 3

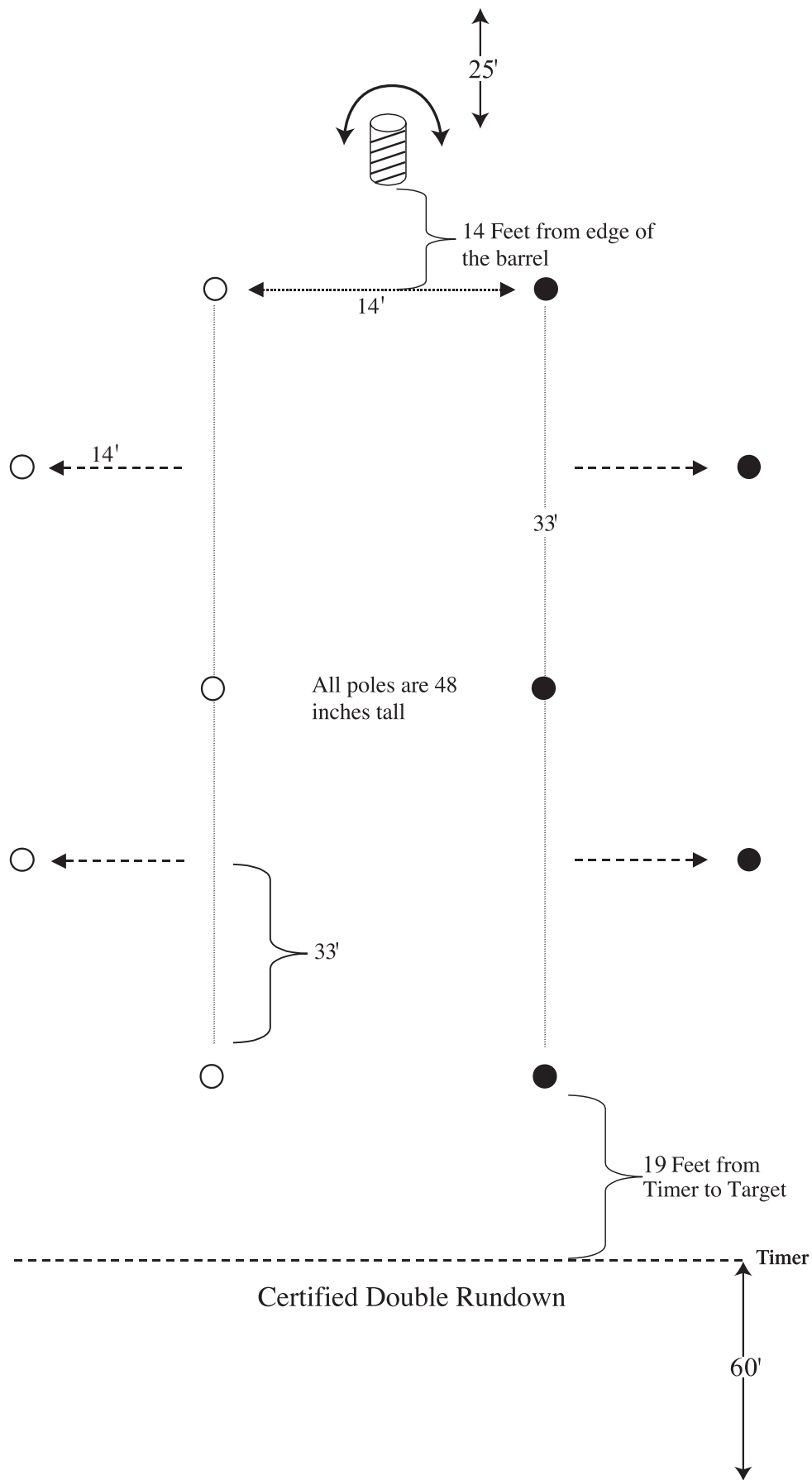

C. Engage 5 of one color, round the barrel(s), engage 5 of the other color
 Procedurals: 2, 3

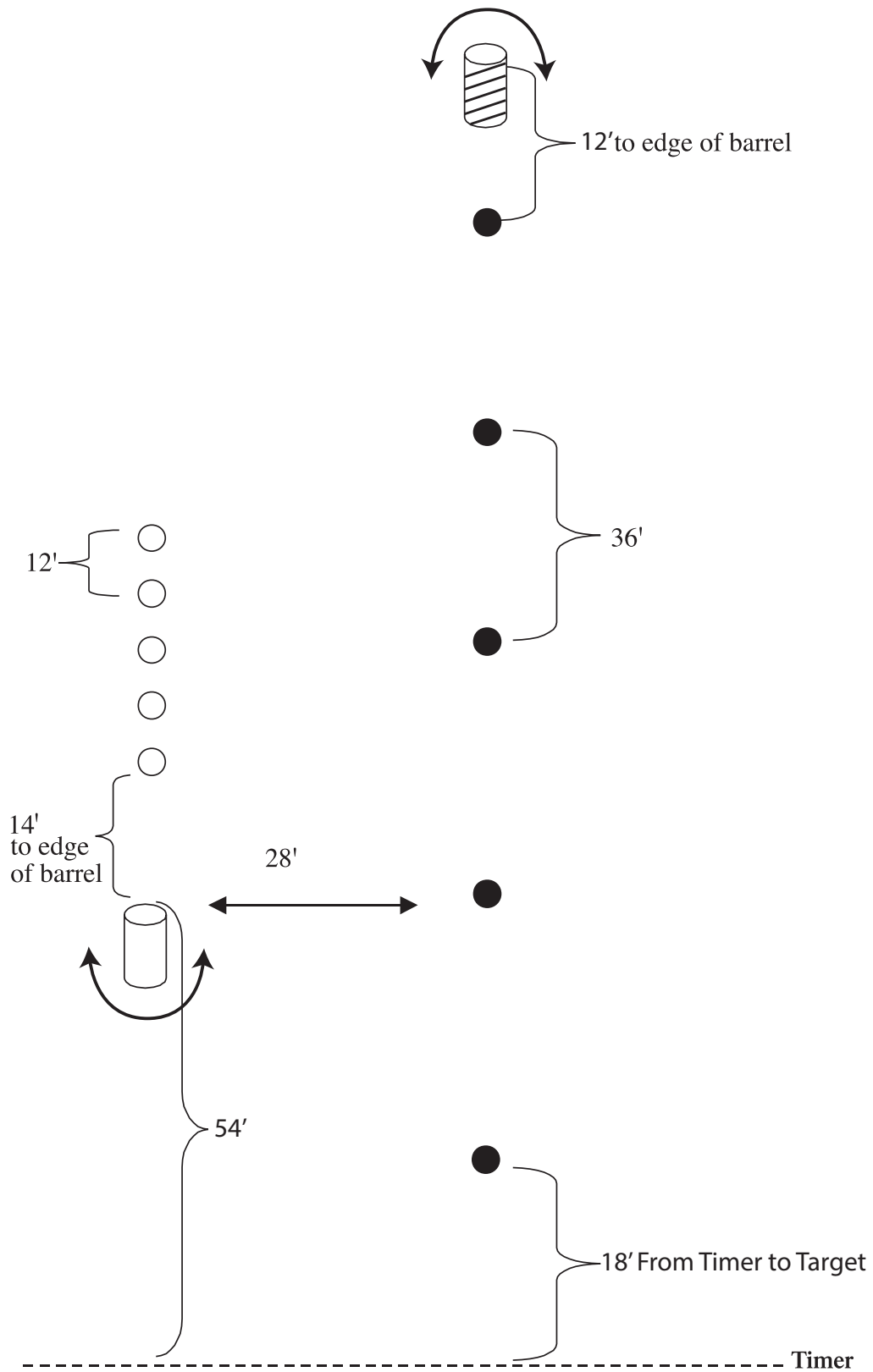

B. Engage the entire Random course first, then round the Random barrel
 Procedurals: 2, 3

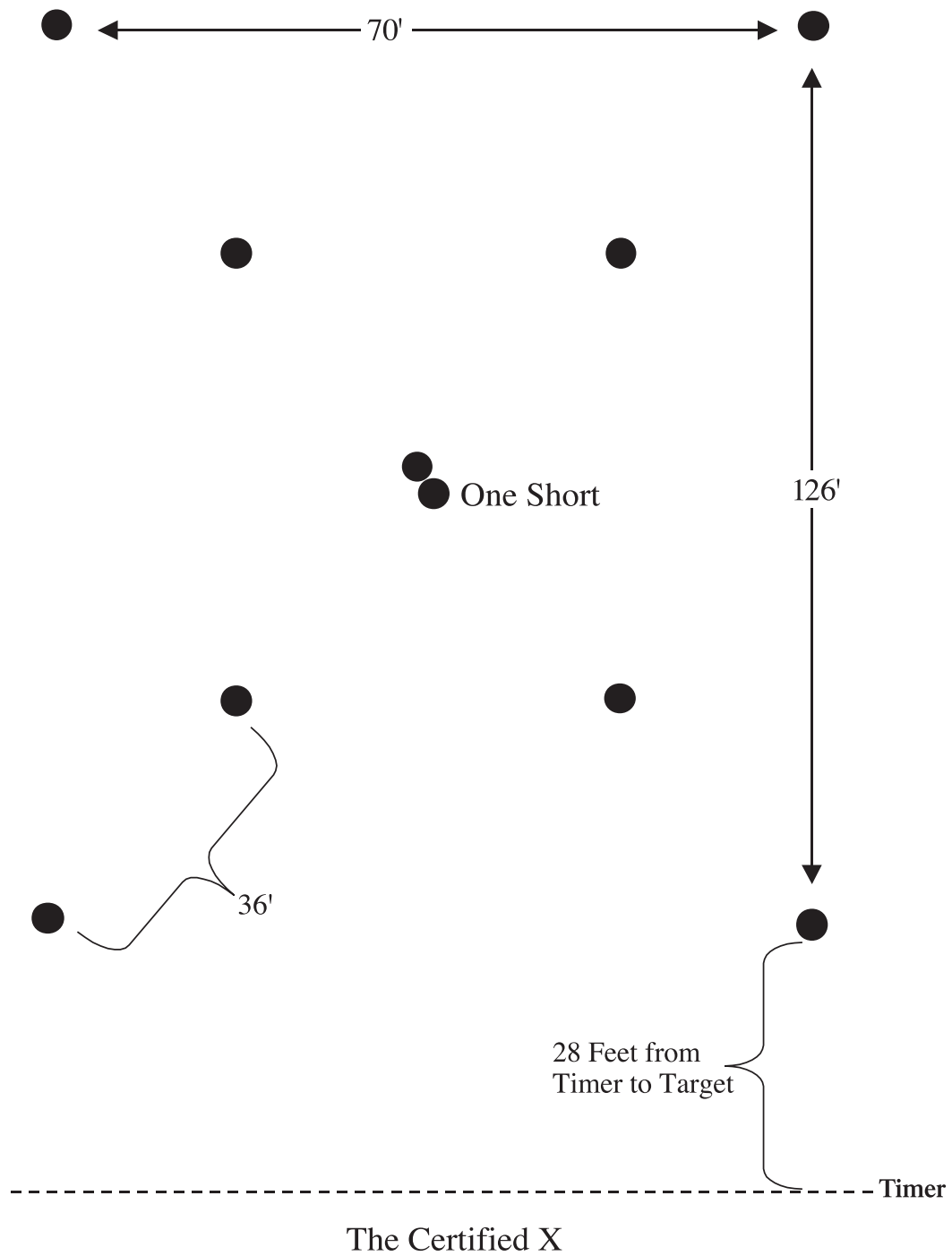

D. Engage 10 targets in any order.

Target shall be the same color.

All poles are 48 inches tall except the center ones, which are 72 inches tall and 24 inches tall.

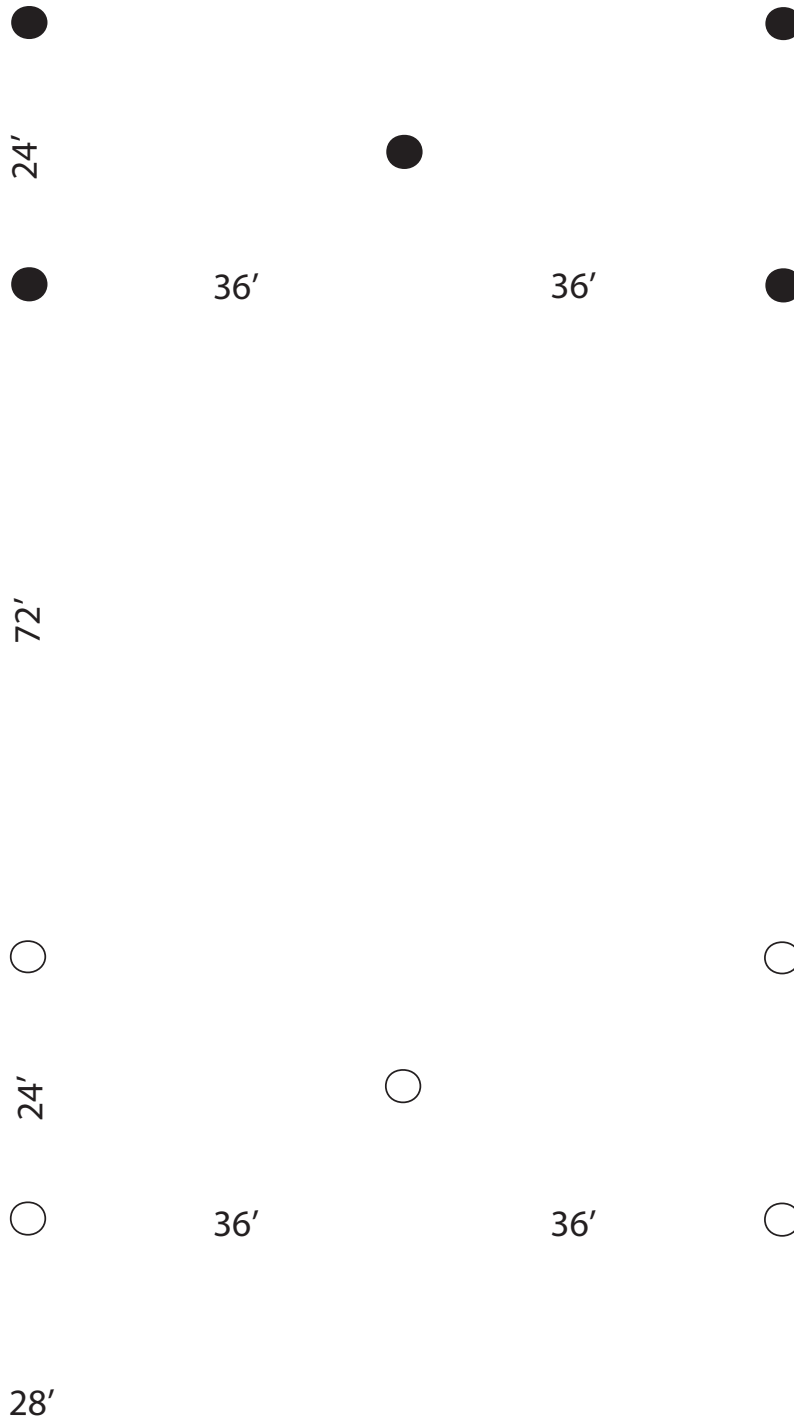

----- Timer

Start/Finish

#55

F. Engage 5 of one color, then engage 5 of the other color.
 Procedurals: 1

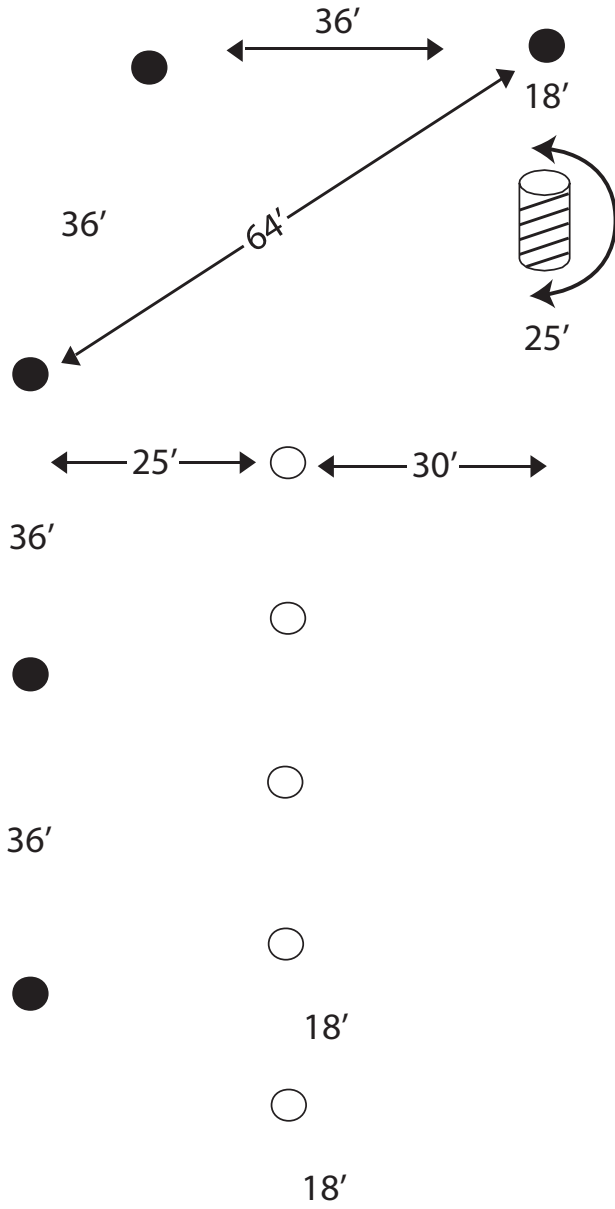

----- Timer

Start/Finish #59

E. Engage all light targets first, then round the Rundown barrel.
 Procedurals: 2, 3

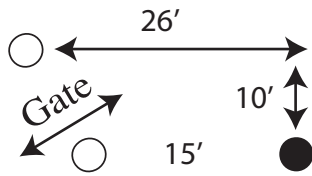
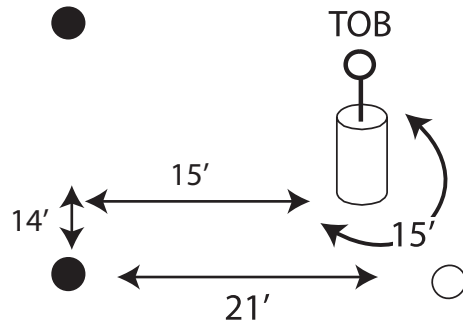

36'

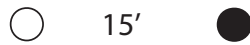

18'

Start/Finish

#60

B. Engage the entire Random course first, then round the Random barrel
 Procedurals: 2

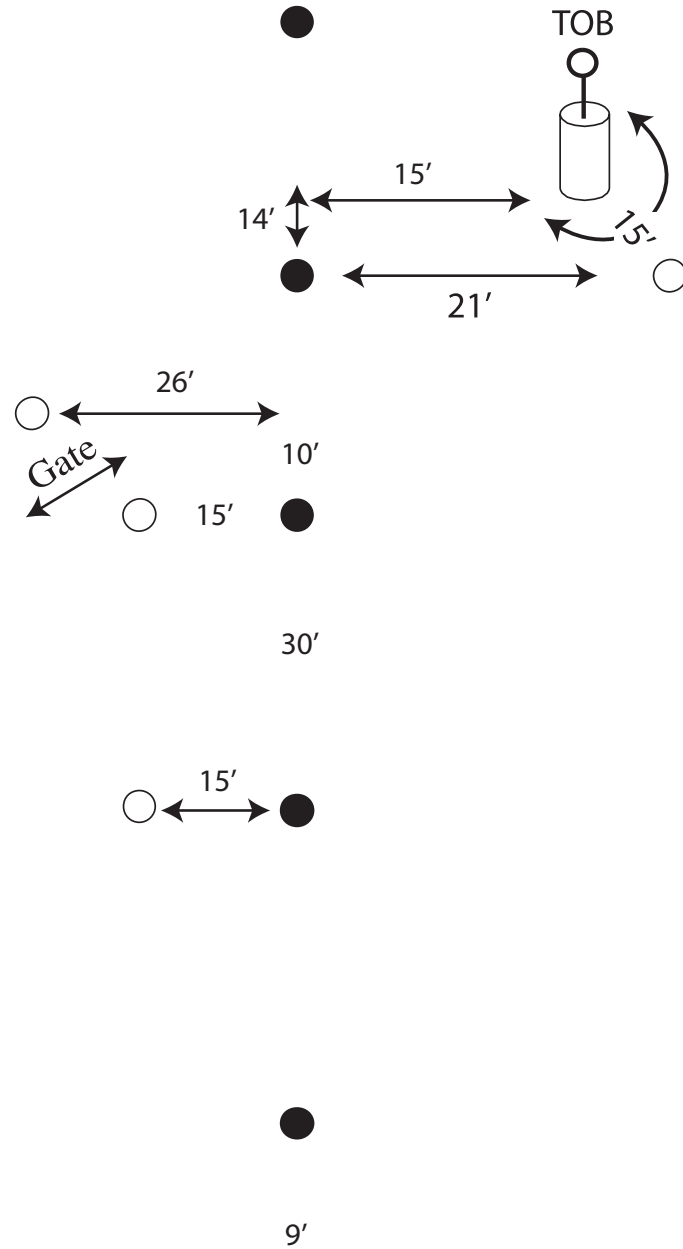

Start/Finish #60s

B. Engage the entire Random course first, then round the Random barrel
 Procedurals: 2

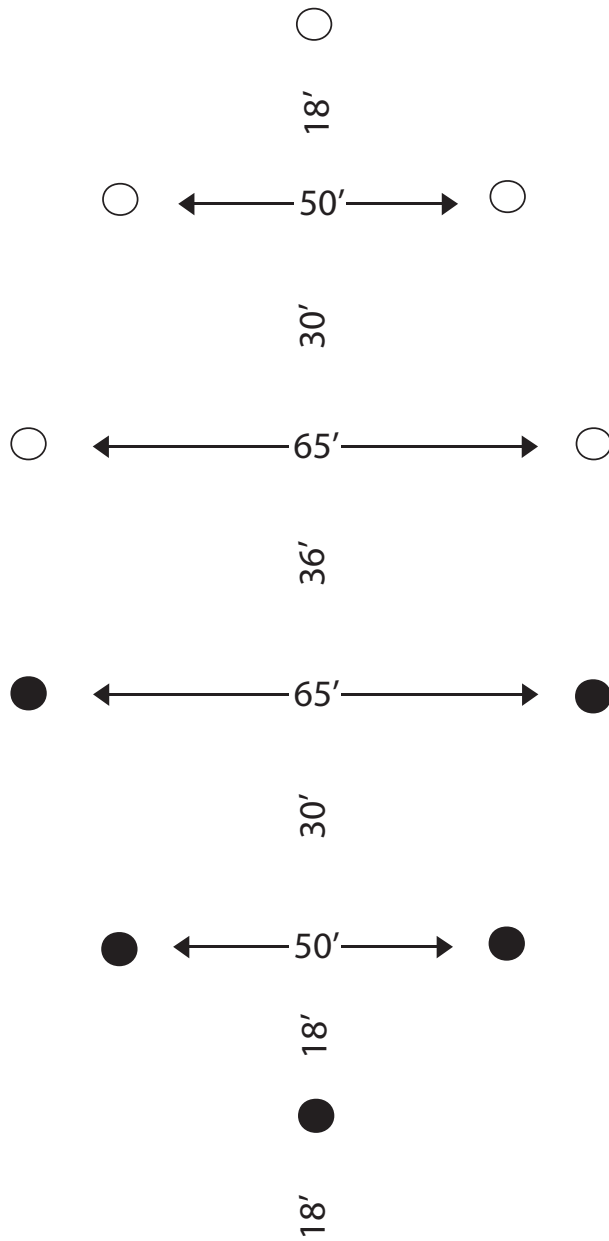

----- Timer

Start/Finish

#61

F. Engage 5 of one color, then engage 5 of the other color.
 Procedurals: 1

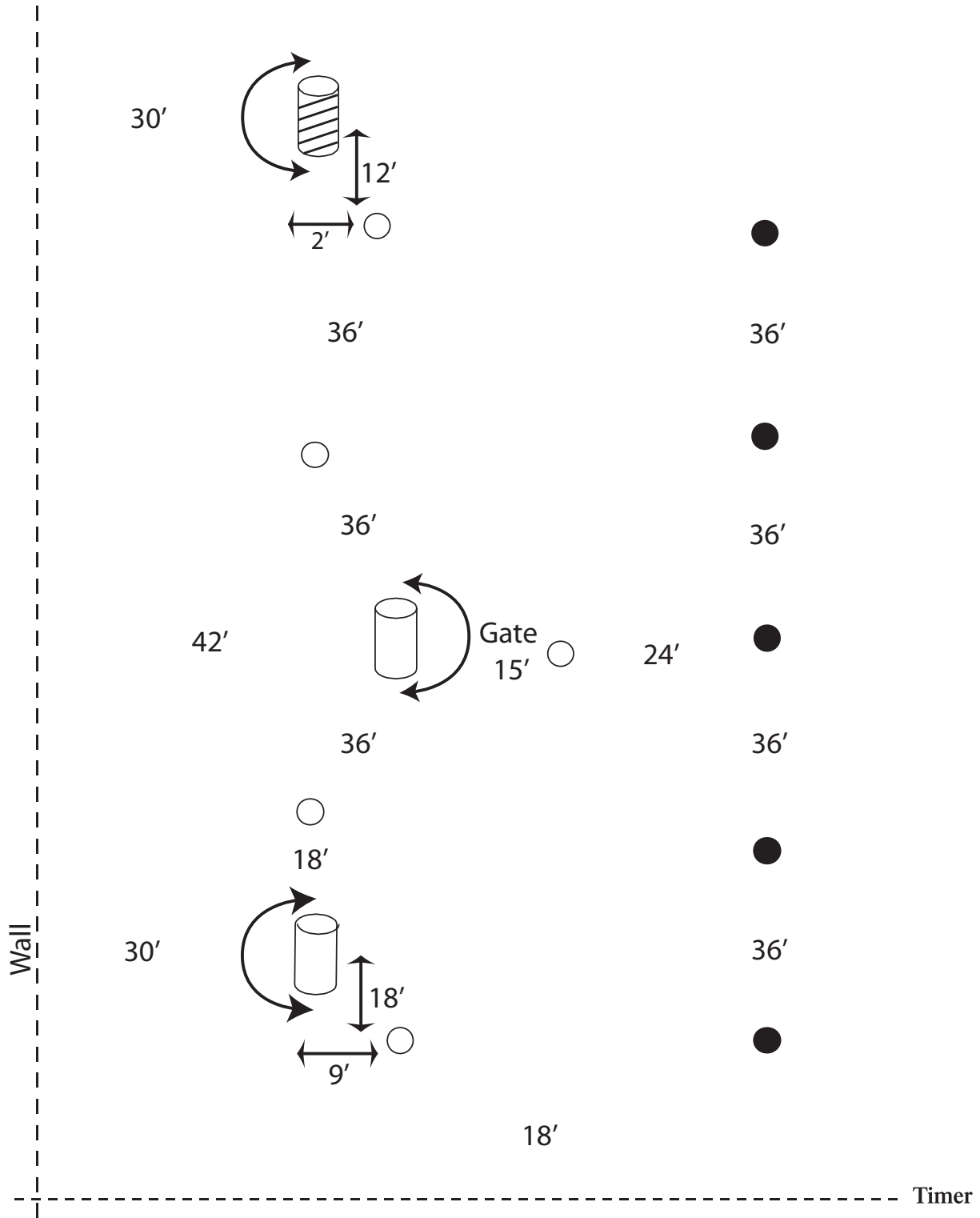

Start/Finish

#62

H. Engage the entire Random course first, then round the Rundown barrel.
 Procedurals: 1, 3

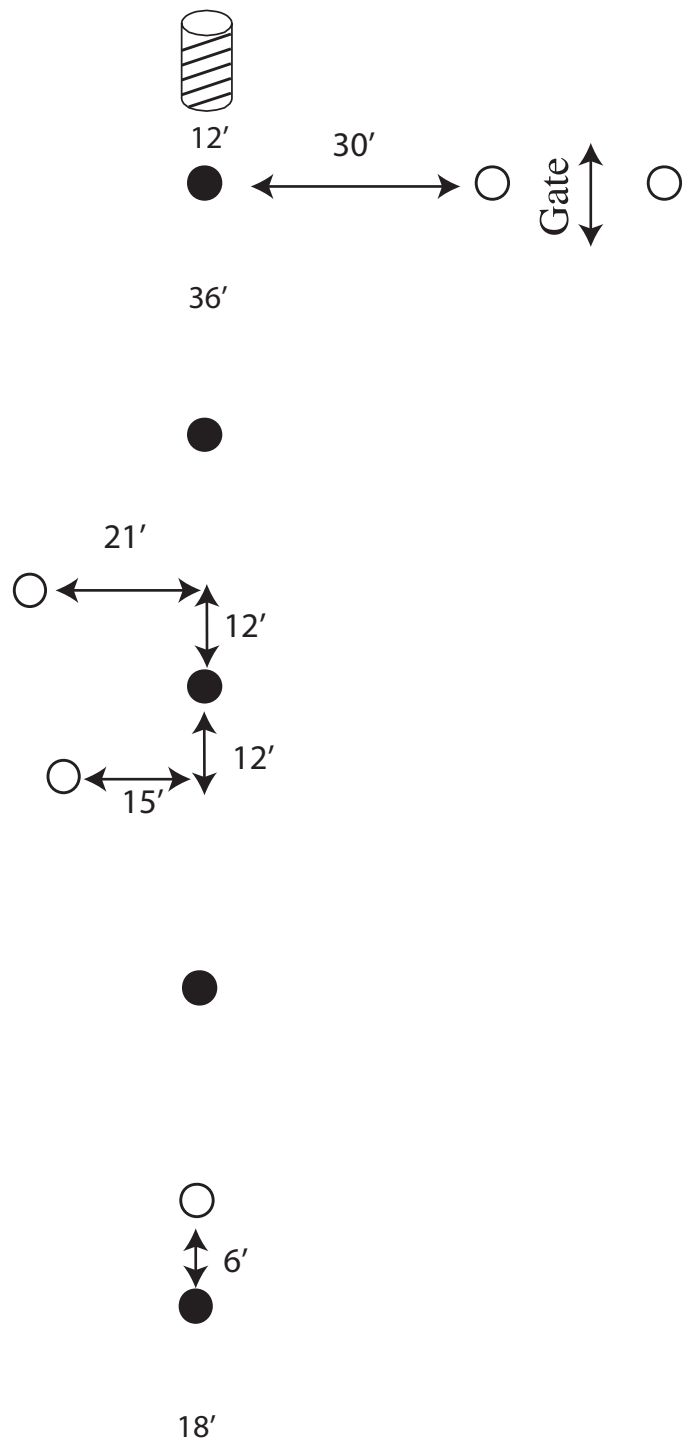

Start/Finish

#63

E. Engage all light targets first, then round the Rundown barrel.
 Procedurals: 2, 3

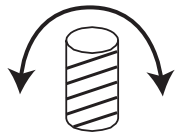

36'

Engage Target on Barrel Last.

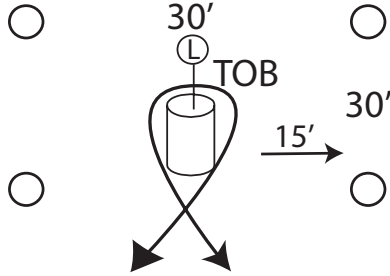

36'

Engage Target on Barrel Last.

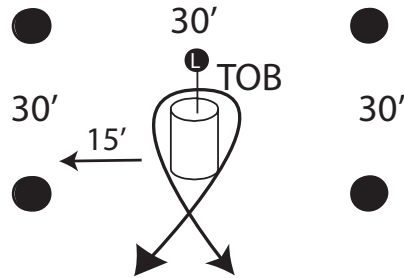

18'

----- Timer

Course 64

Engage 5 of one color, round the Rundown barrel, engage 5 of the other color, round the barrel.

Procedurals: 2, 3



12'



36'

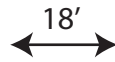

25'

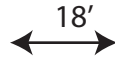
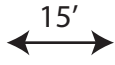

18'

Start/Finish

#66

E. Engage all light targets first, then round the Rundown barrel.
Procedurals: 2, 3

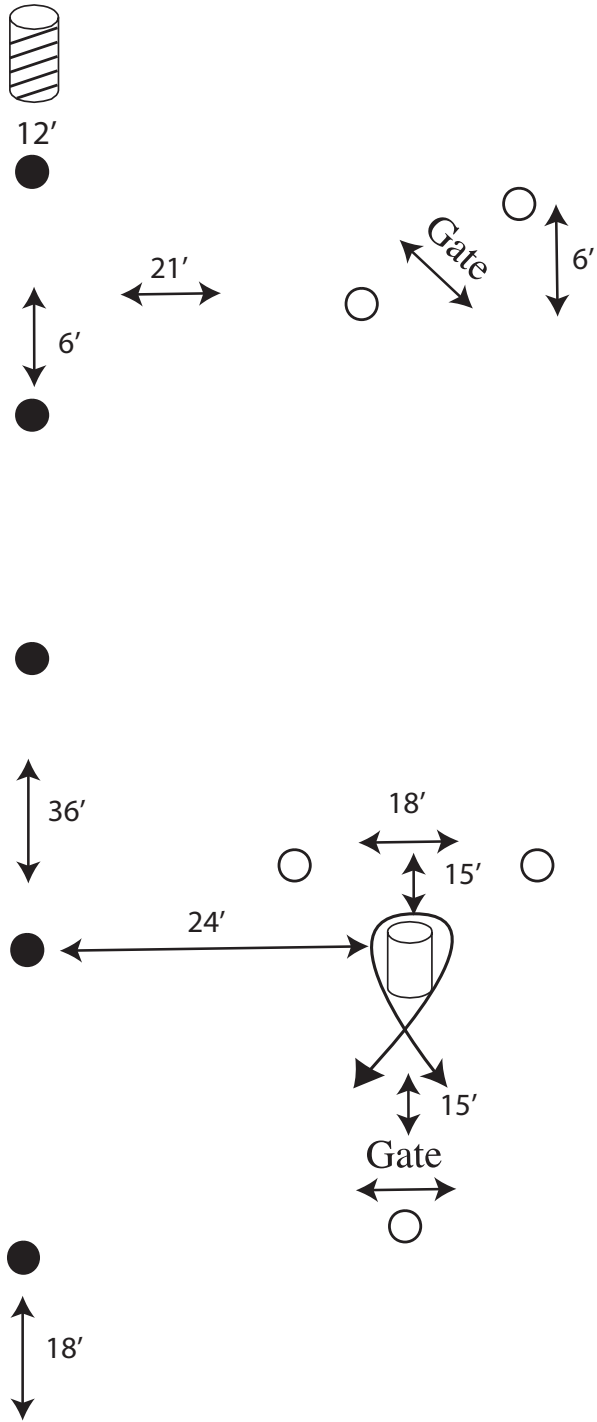

Start/Finish

#68

H. Engage the entire Random course first, then round the Rundown barrel.
 Procedurals: 1, 2, 3

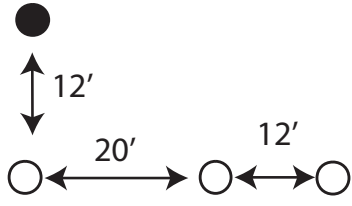
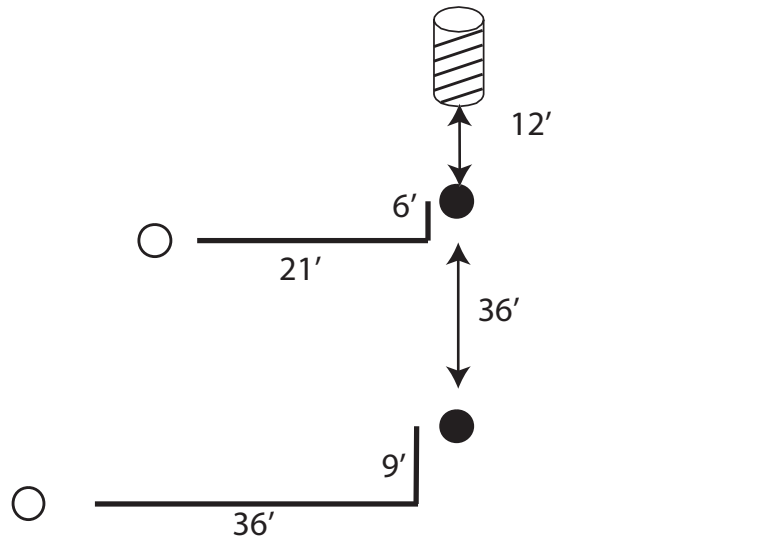

Start/Finish

#69

E. Engage all light targets first, then round the Rundown barrel.
 Procedurals: 2, 3
 Course 69

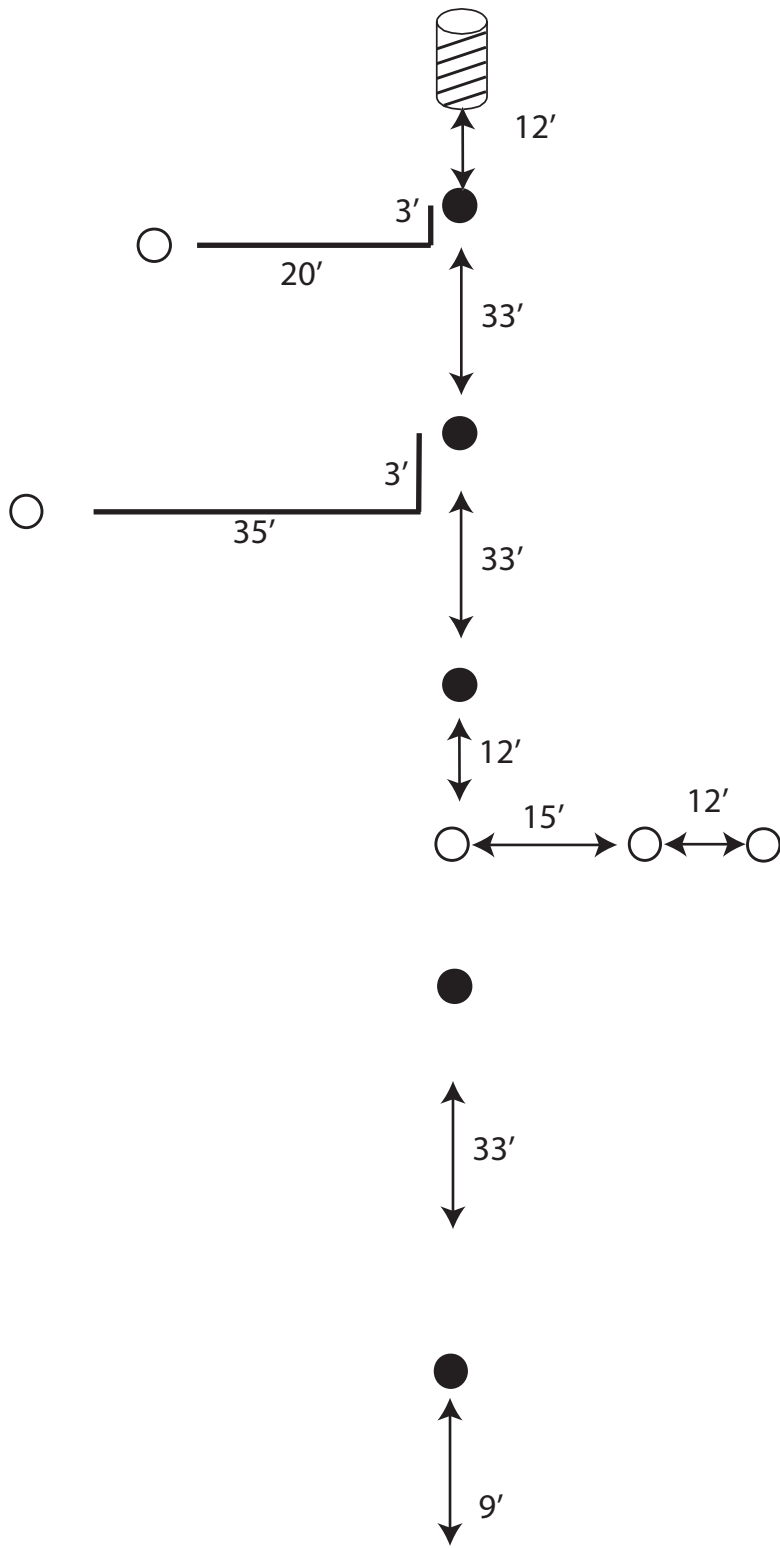

Start/Finish

#69s

E. Engage all light targets first, then round the Rundown barrel.
 Procedurals: 2, 3

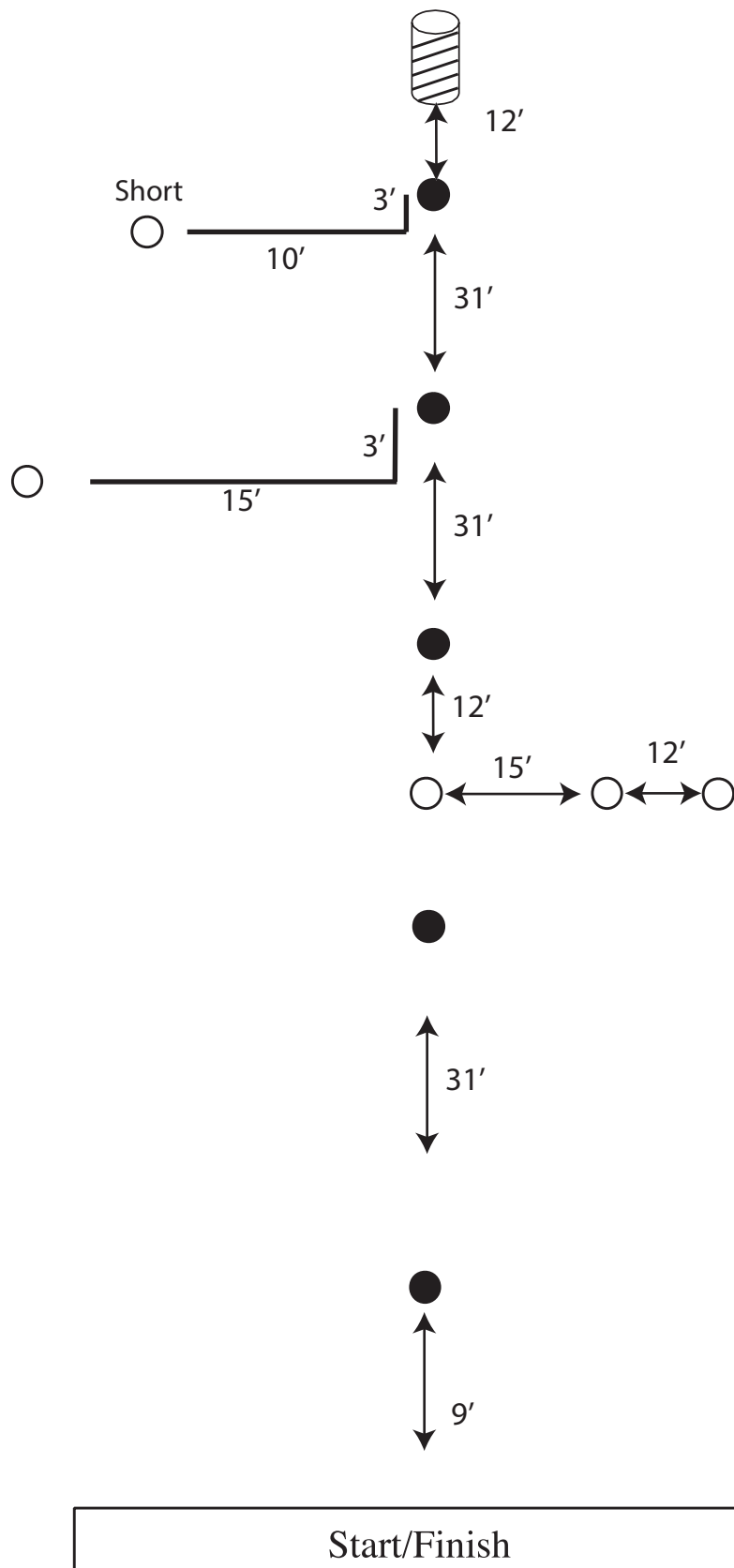

#69ss

E. Engage all light targets first, then round the Rundown barrel.
 Procedurals: 2, 3

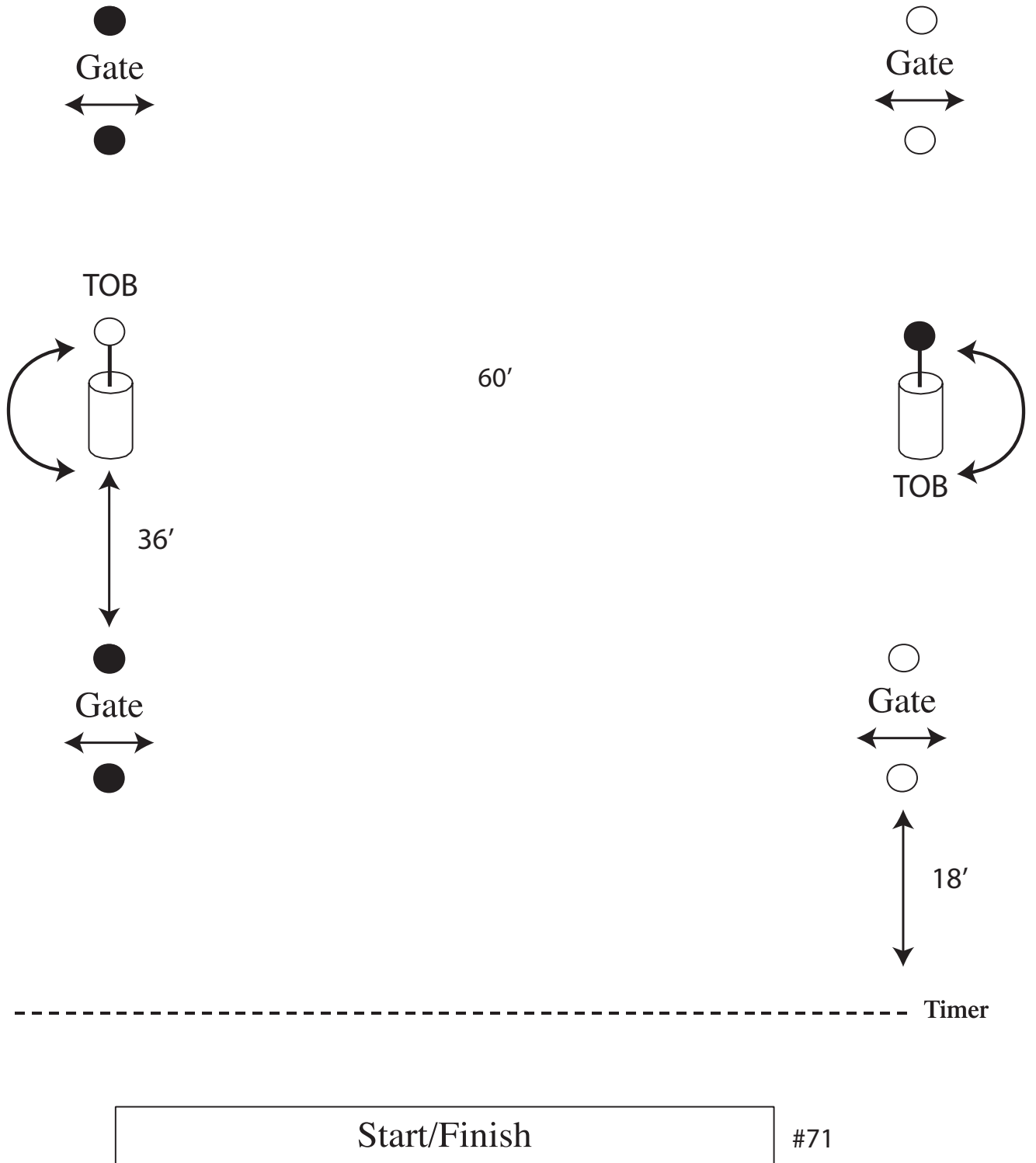

G. Engage 5 of one color, then engage 5 of the other color.
 Procedurals: 1

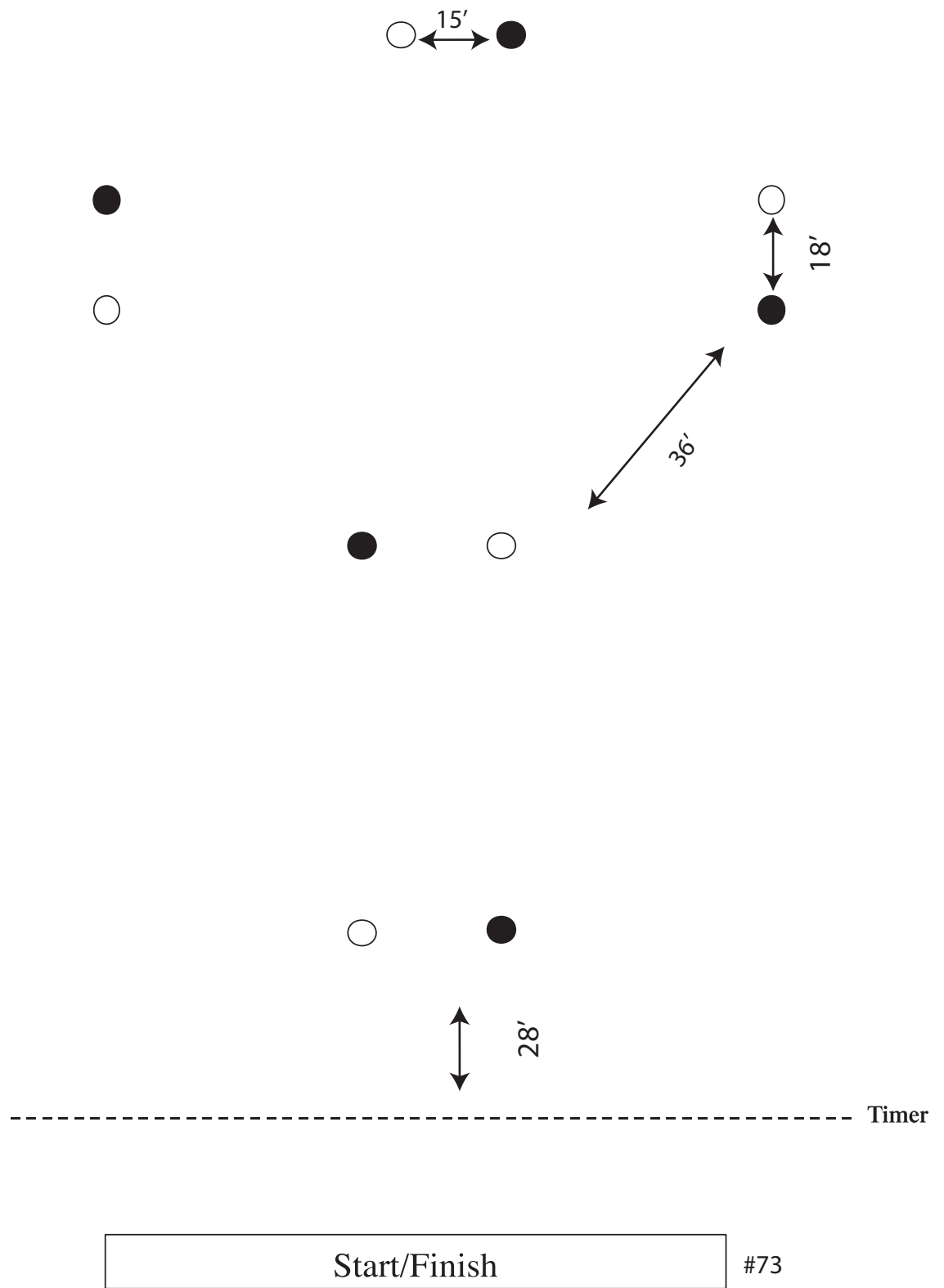

G. Engage 5 of one color, then engage 5 of the other color.
 Procedurals: 1

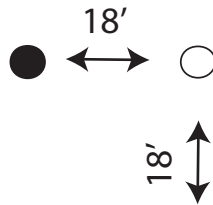
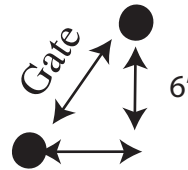
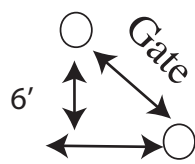
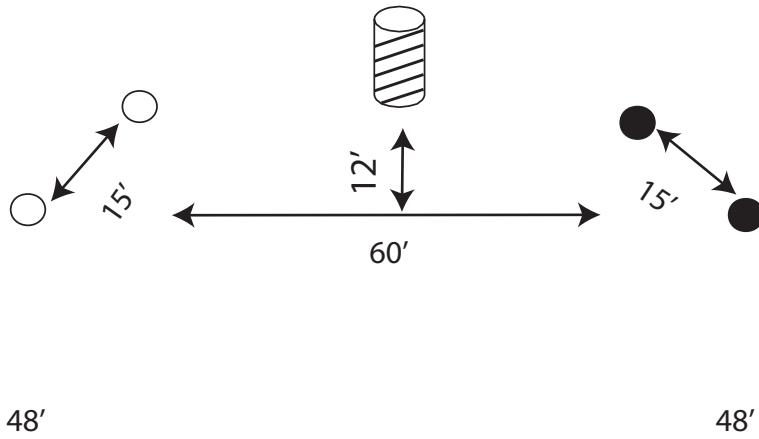

----- Timer

Start/Finish #74

C. Engage 5 of one color, round the Rundown barrel, then engage 5 of the other color.
 Procedurals: 1, 3

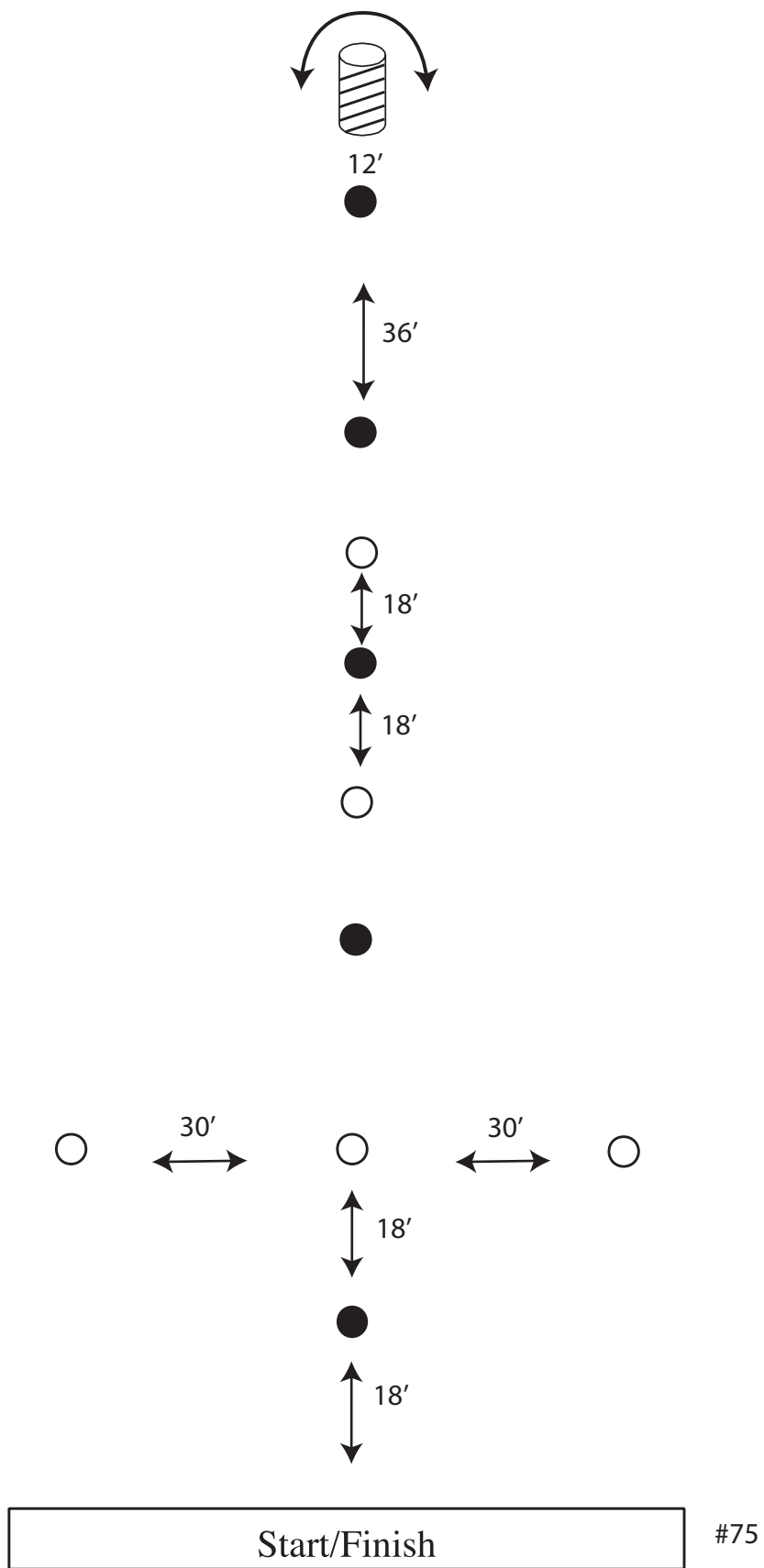

Rifle/Shotgun Course

H. Engage the entire Random course first, then round the Rundown barrel.

Procedurals: 1, 2, 3

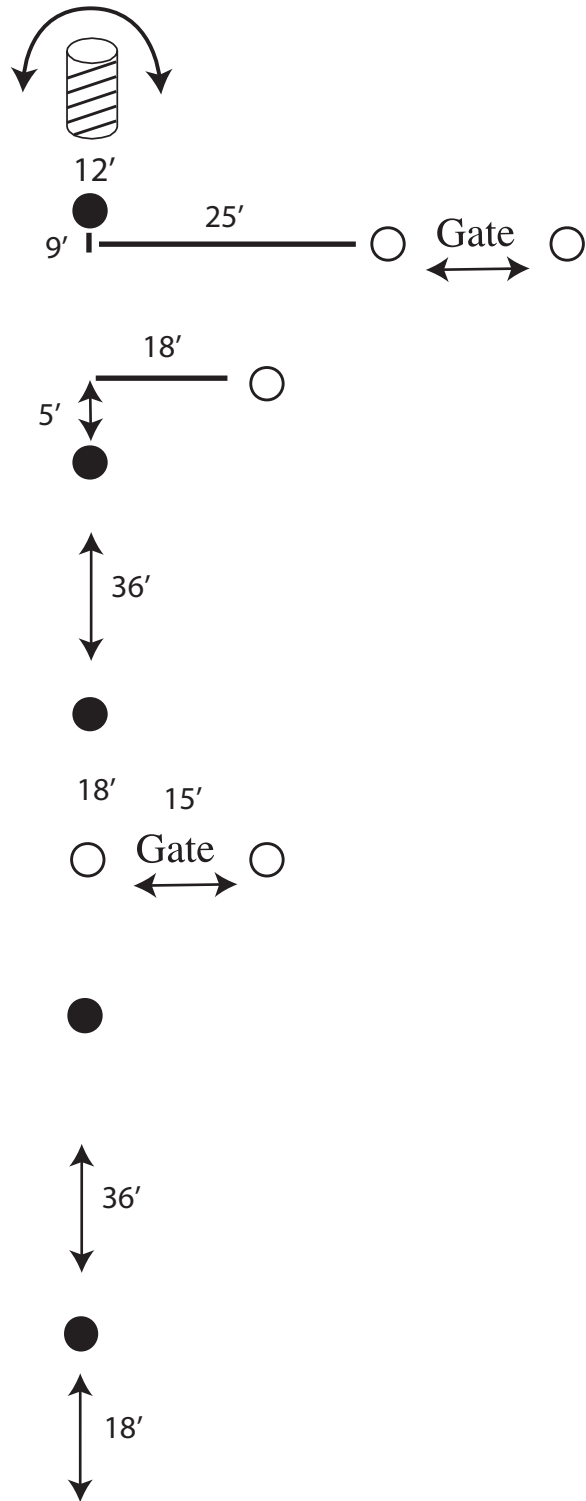

Start/Finish

#76

H. Engage the entire Random course first, then round the Rundown barrel.
 Procedurals: 1, 2, 3

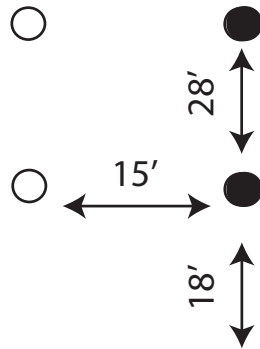
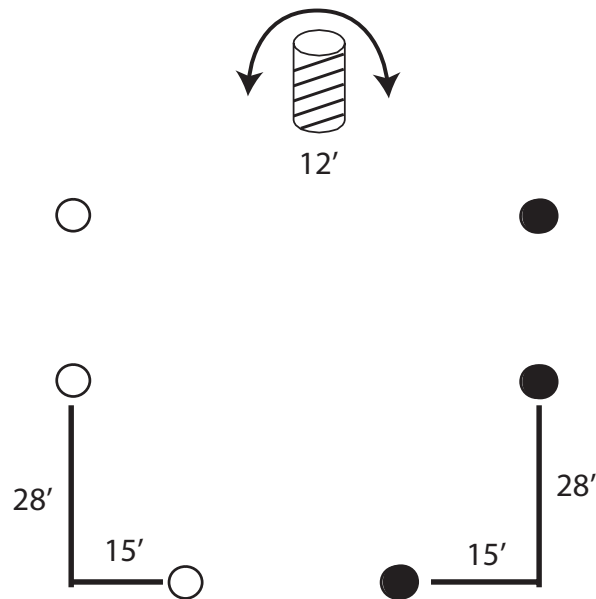

----- Timer

Start/Finish

#77S

C. Engage 5 of one color, round the Rundown barrel, then engage 5 of the other color.
 Procedurals: 1, 3

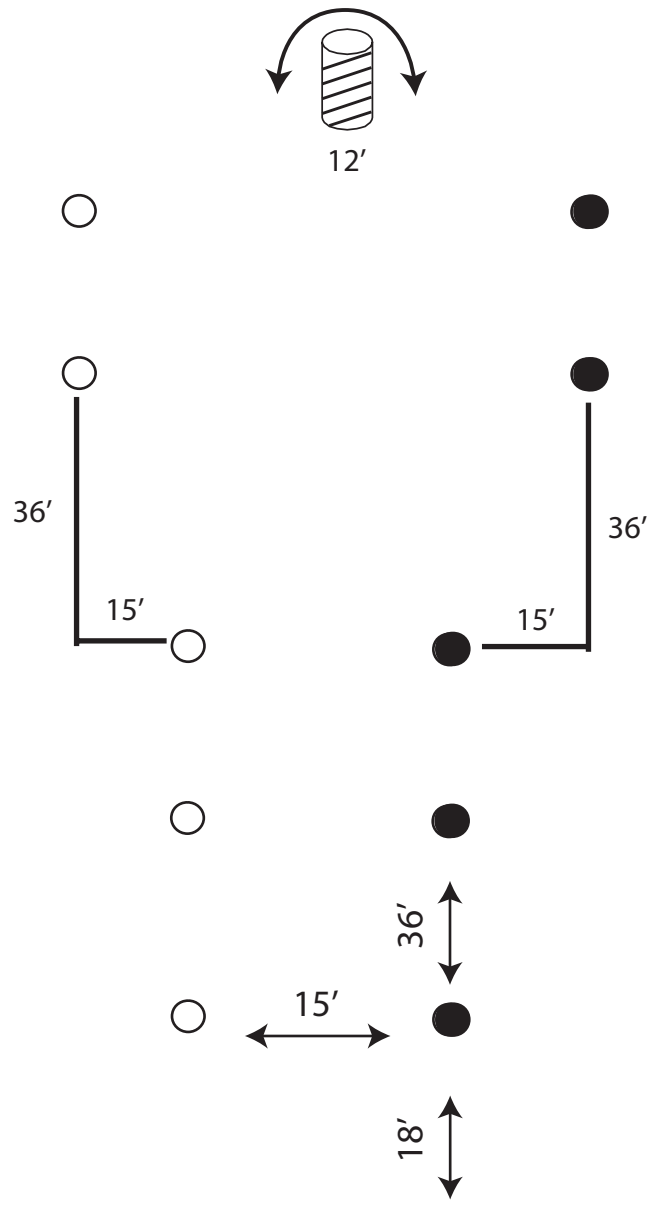

----- Timer

Start/Finish

#77

C. Engage 5 of one color, round the Rundown barrel, then engage 5 of the other color.
 Procedurals: 1, 3

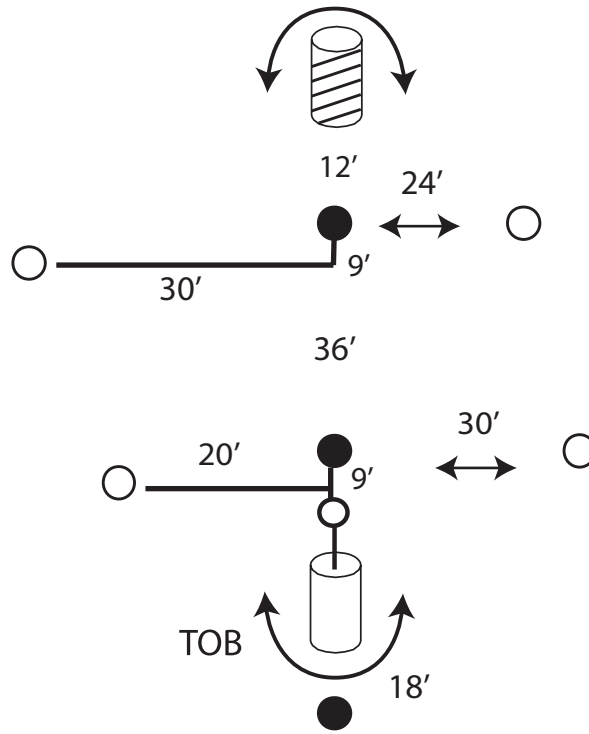

36'



18'

Start/Finish

#78

Rifle/Shotgun Course

H. Engage the entire Random course first, then round the Random Barrel. Then round the Rundown barrel.

Procedurals: 1, 2, 3

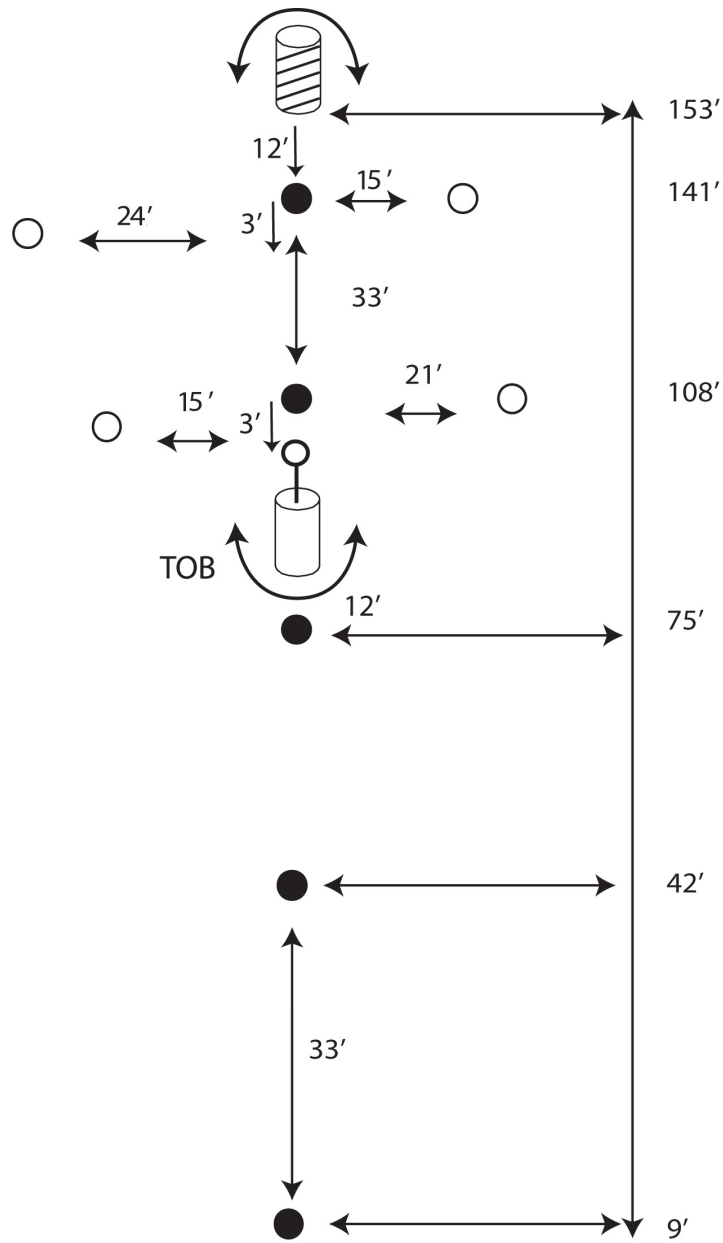

Start/Finish

 #78s

H. Engage the entire Random course first, then round the Random Barrel. Then round the Rundown barrel.
 Procedurals: 1, 2, 3

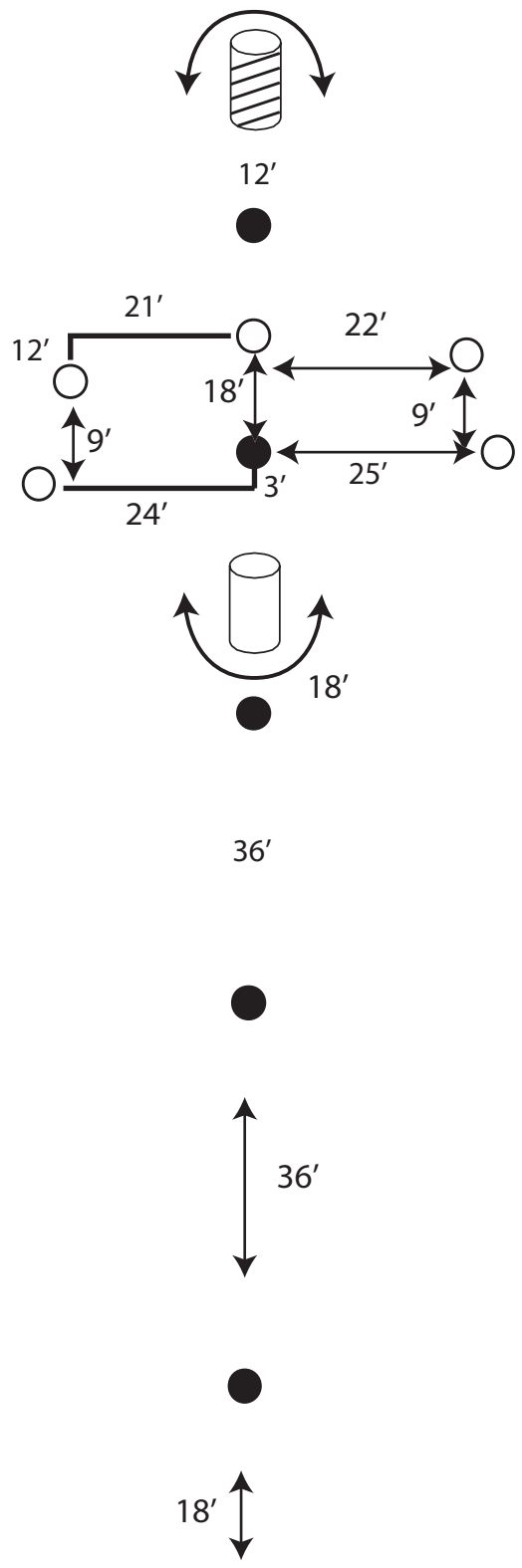

Start/Finish

#79

Rifle/Shotgun Course

H. Engage the entire Random course first, then round the Random Barrel. Then round the Rundown barrel.
 Procedurals: 1, 2, 3

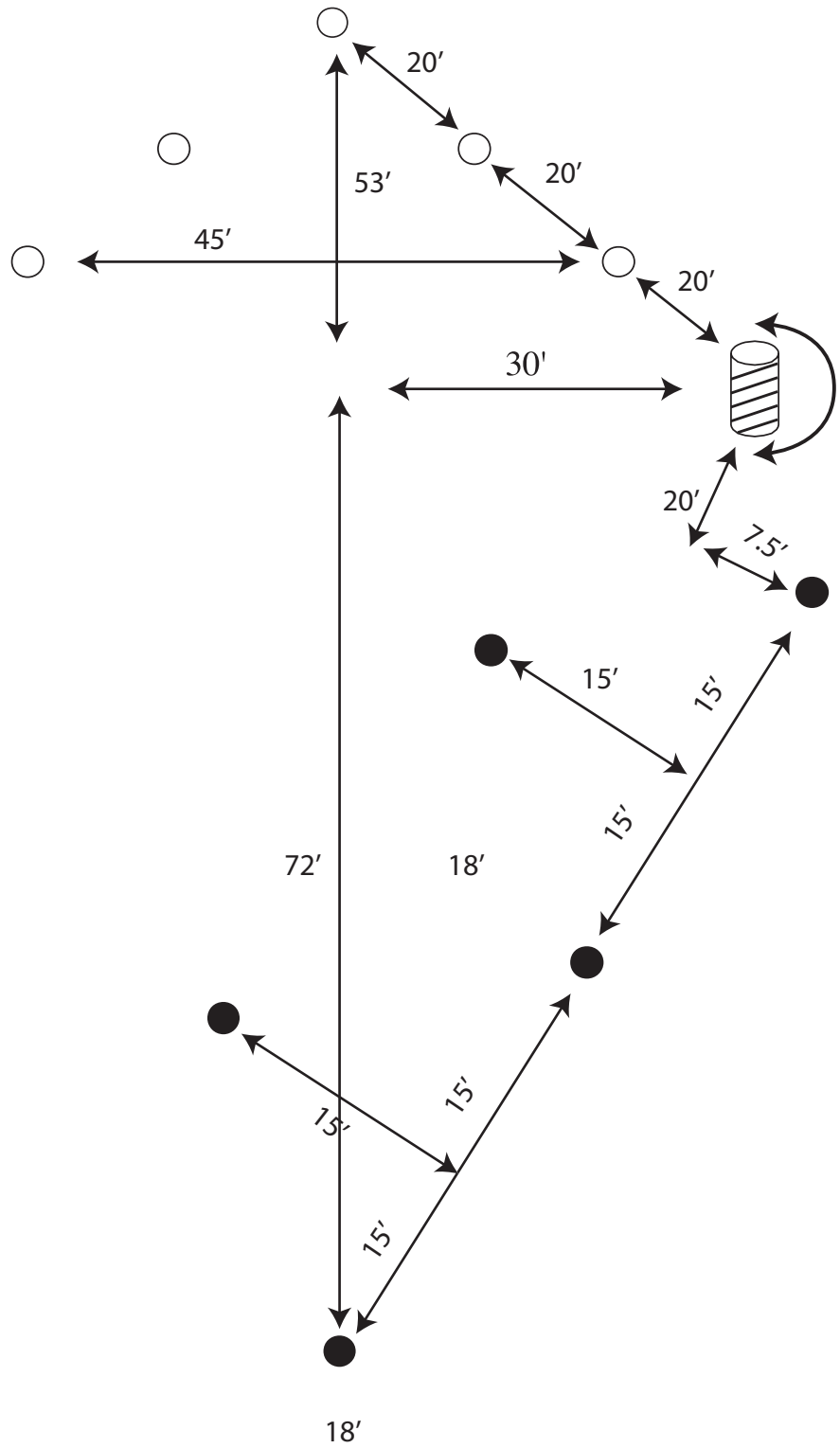

Start/Finish

#82

C. Engage 5 of one color, round the barrel, engage 5 of the other color
 Procedurals 1, 2, 3

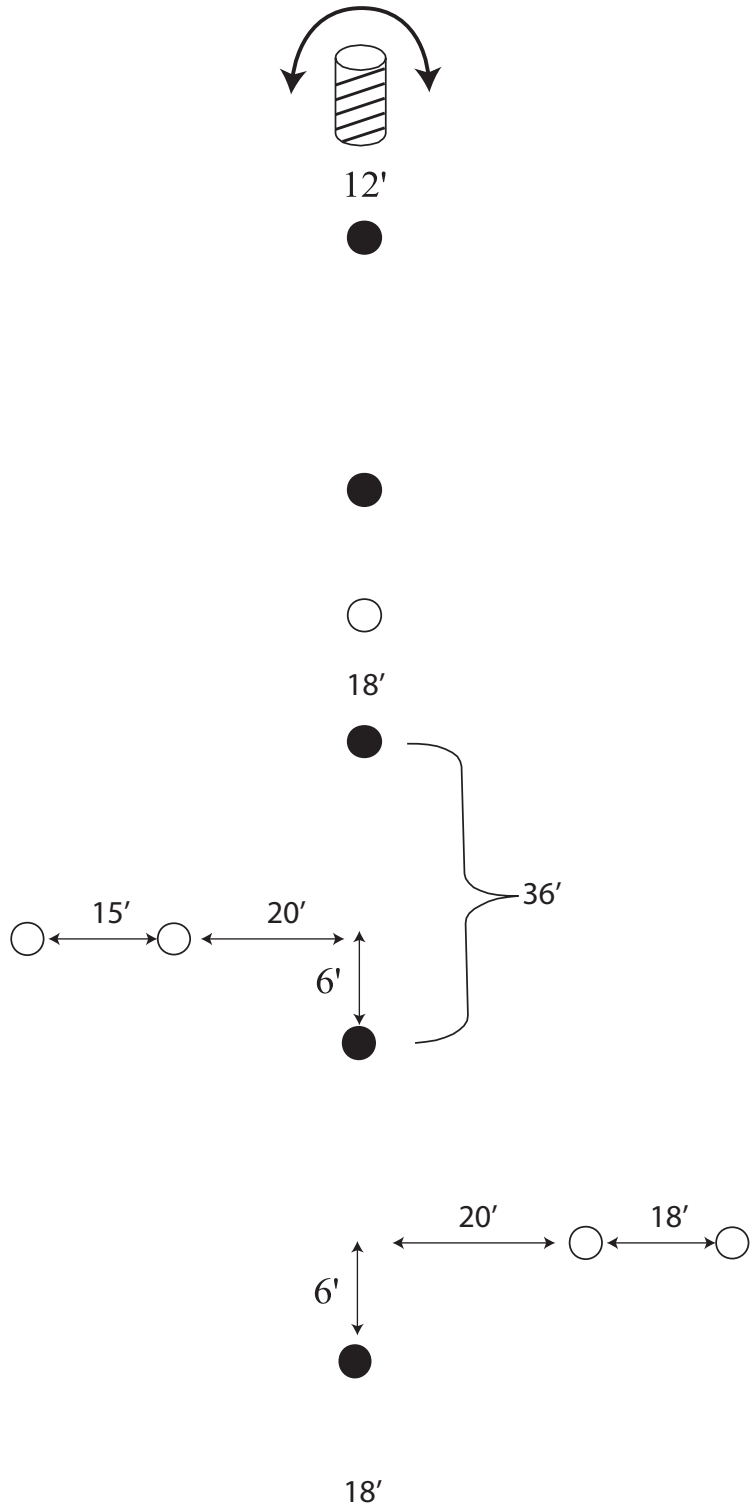

Start/Finish

#83

E. Engage all light targets first, then round the Rundown barrel.
 Procedurals 1, 2, 3

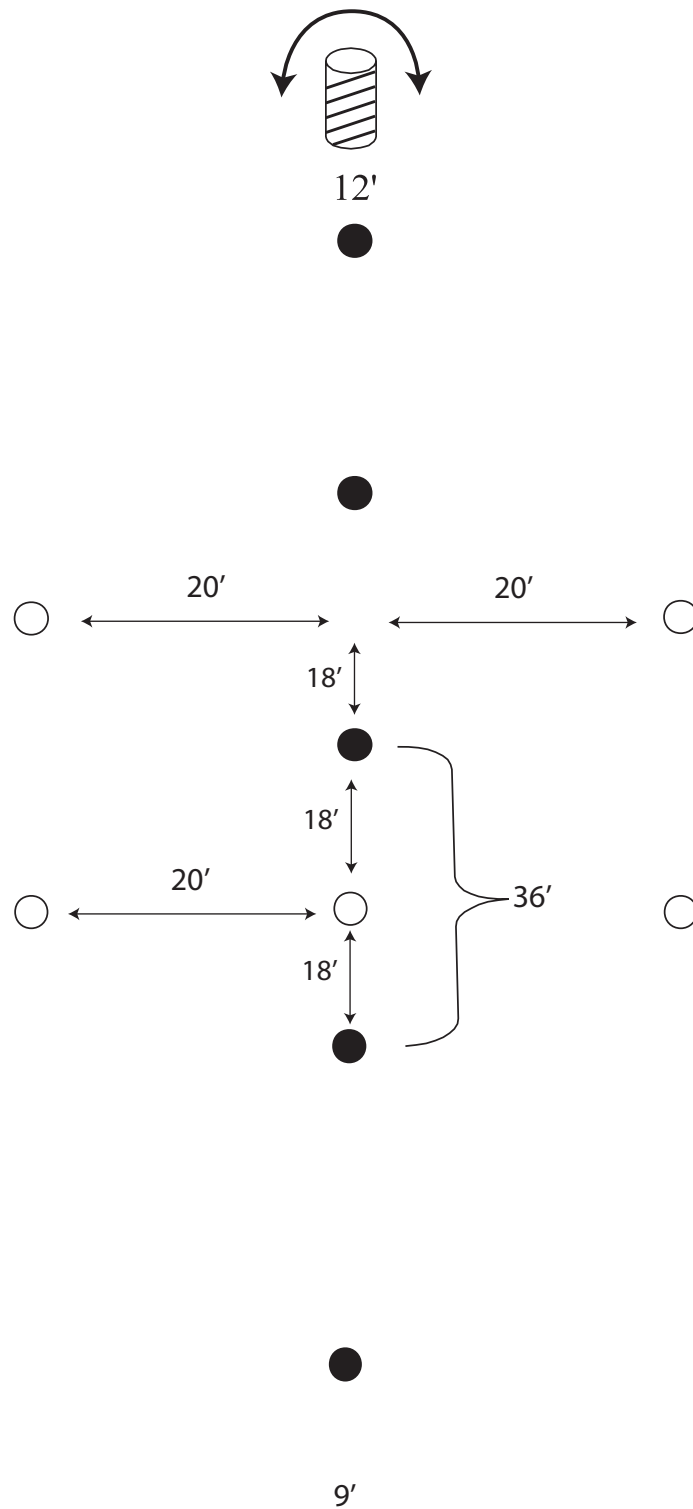

Start/Finish

#84

Rifle/Shotgun Course
 E. Engage all light targets first, then round the Rundown barrel.
 Procedurals 1, 2, 3

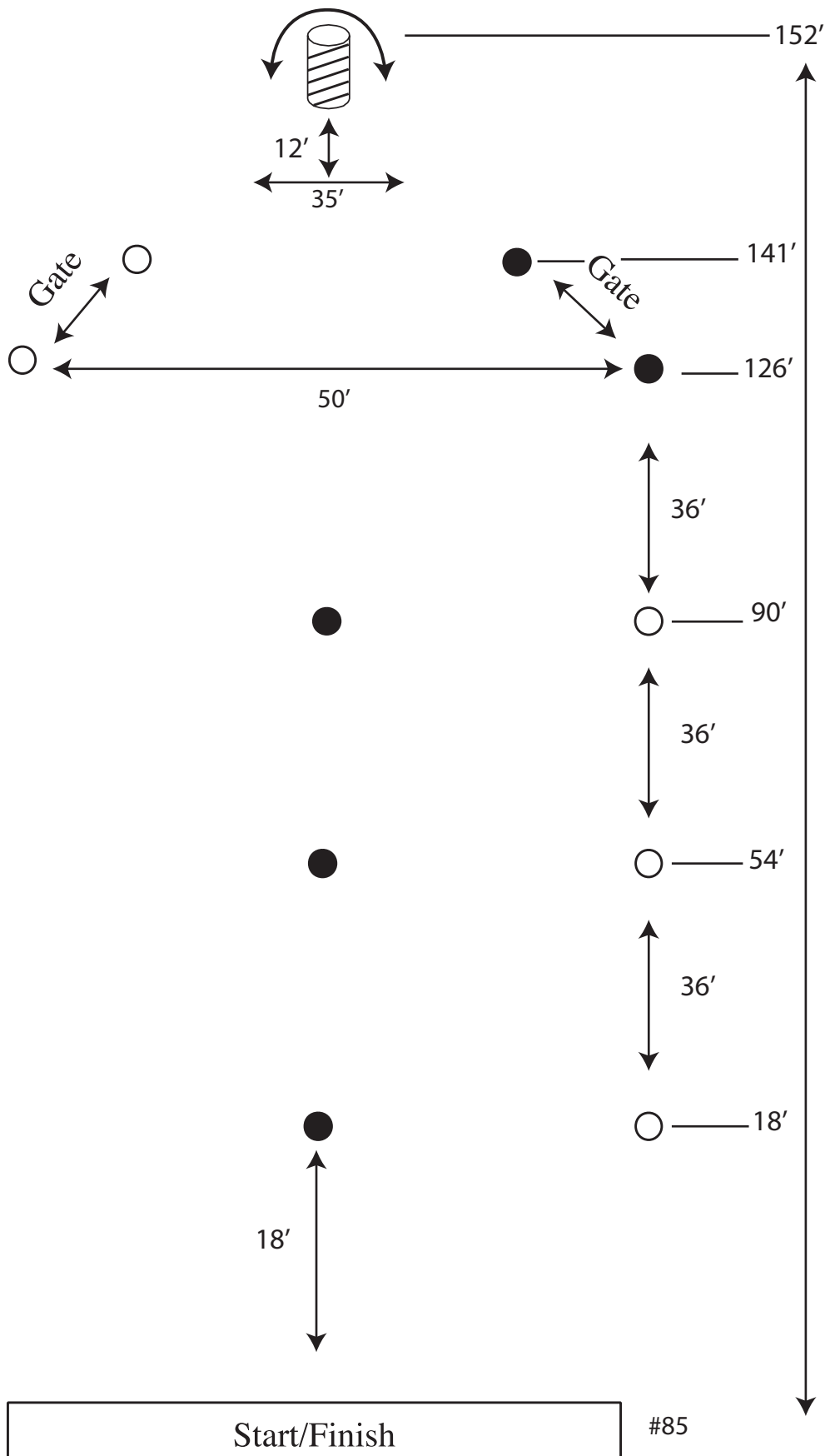

E. Engage all light targets first, then round the Rundown barrel
 Procedurals: 1, 2, 3

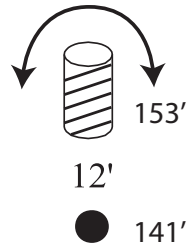

12'

153'

● 141'

● 108'

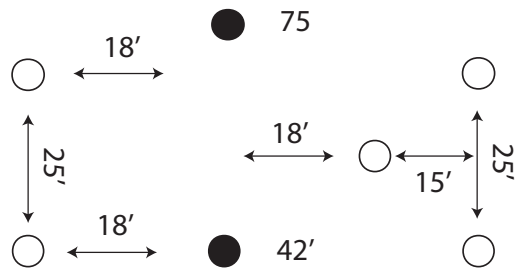

● 75

● 42'

● 9'

Start/Finish

#86s

E. Engage all light targets first, then round the Rundown barrel.
 Procedurals 1, 2, 3

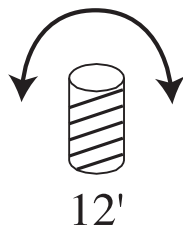

Either side may go between poles.

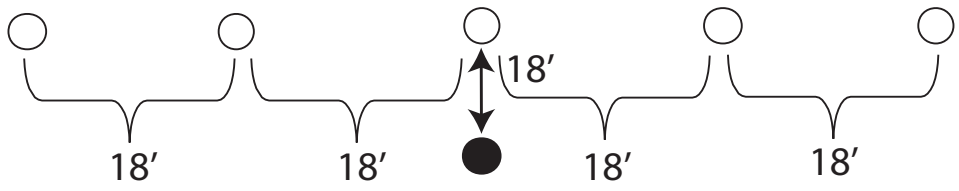
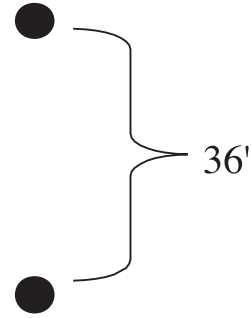

All poles are 48 inches tall

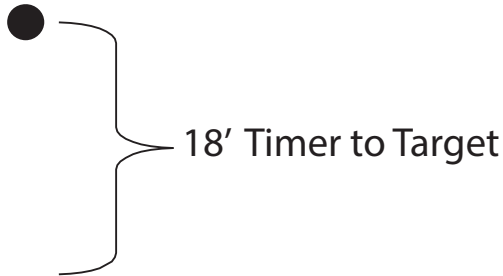

E. Engage all light targets first, then round the Rundown barrel.
 Procedurals: 2, 3
 Rifle/Shotgun Course

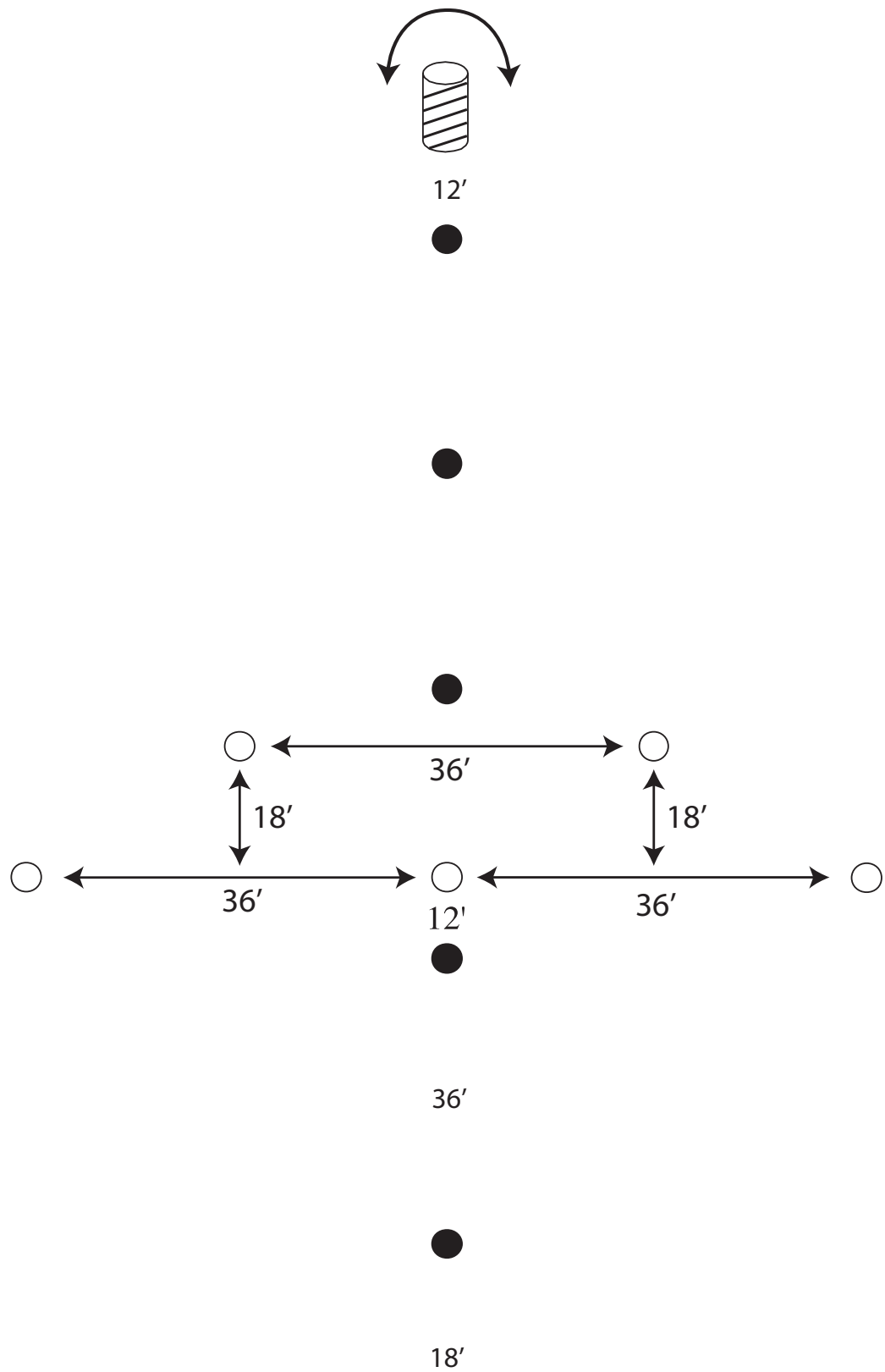

Start/Finish

#88

Rifle/Shotgun Course
 H. Engage the entire Random course first, then round the Rundown barrel.
 Procedural: 2

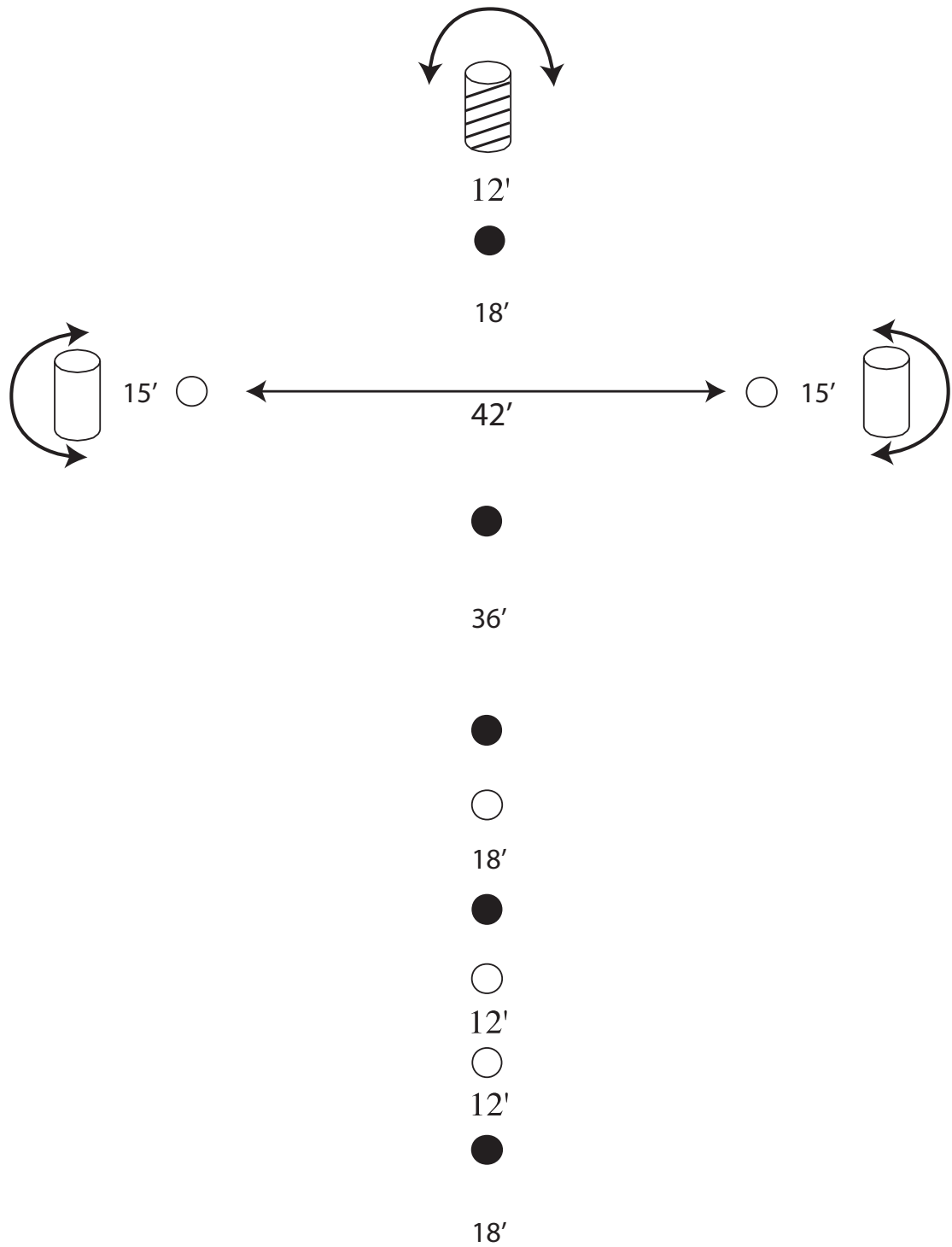

Start/Finish

#89

Rifle/Shotgun Course

H. Engage the entire Random course first, then round the Rundown barrel.

Procedural: 2

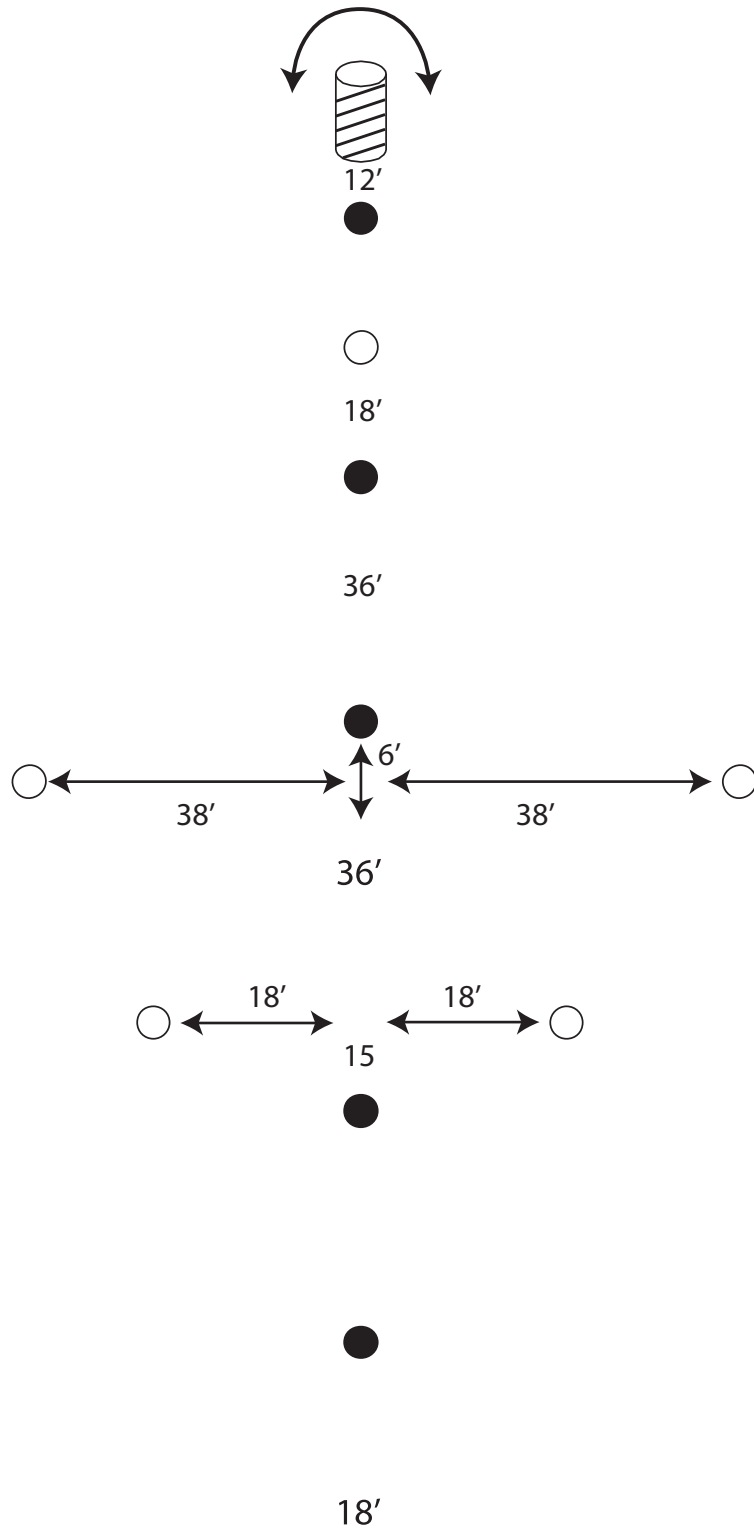

Start/Finish

#90

Rifle/Shotgun Course

H. Engage the entire Random course first, then round the Rundown barrel.

Procedural: 2, 3

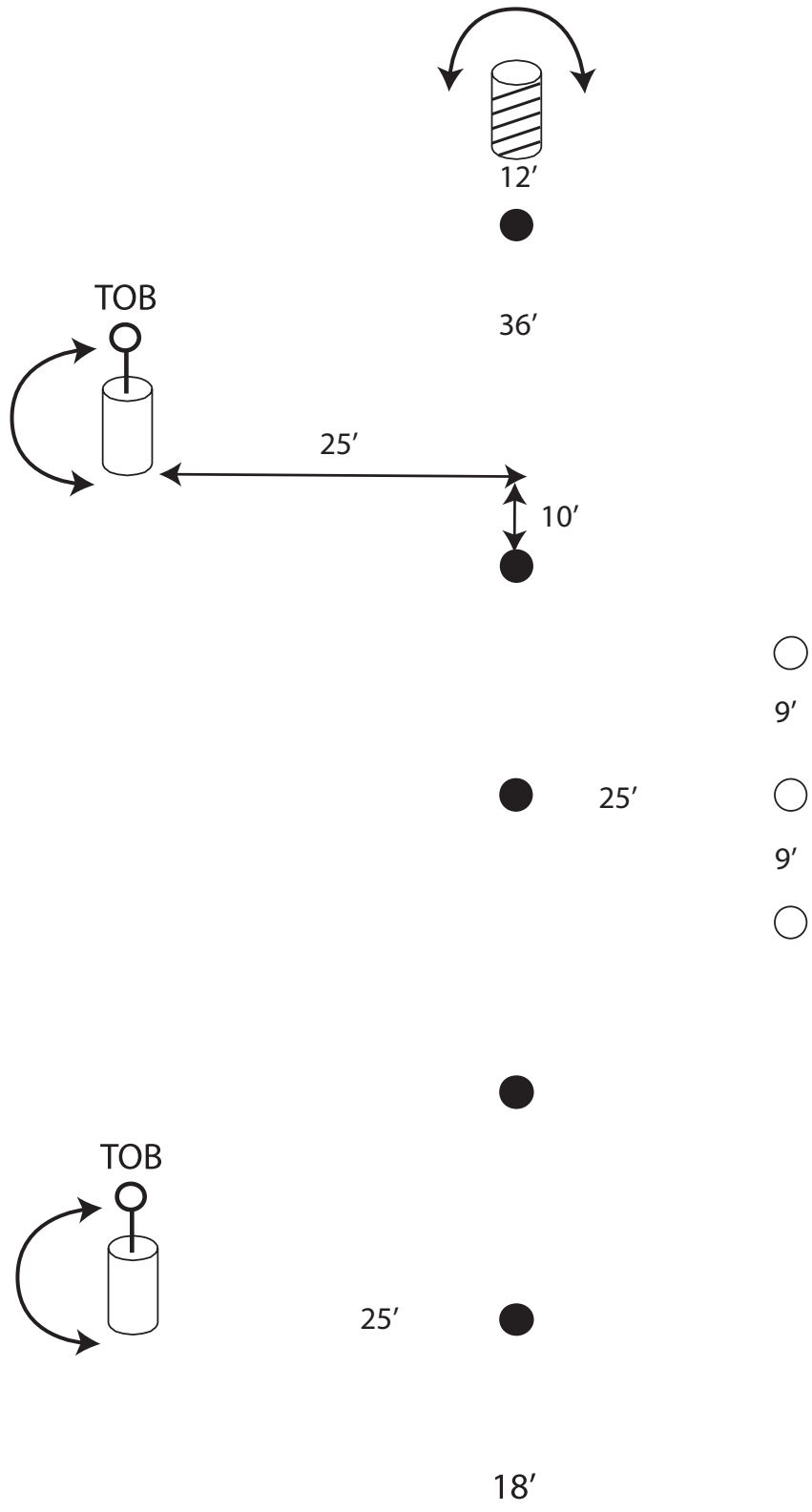

Start/Finish

#91

H. Engage the entire Random course first, then round the Rundown barrel.

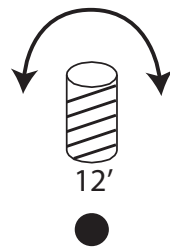

36'

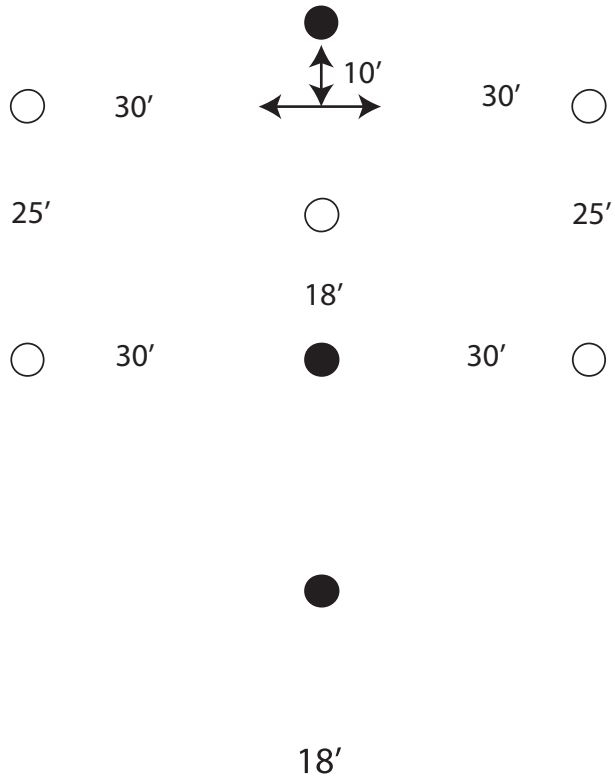

Start/Finish

#92

Rifle/Shotgun Course

H. Engage the entire Random course first, then round the Rundown barrel.

Procedural: 2, 3

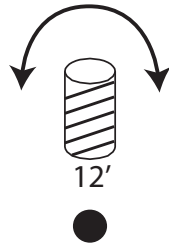

36'

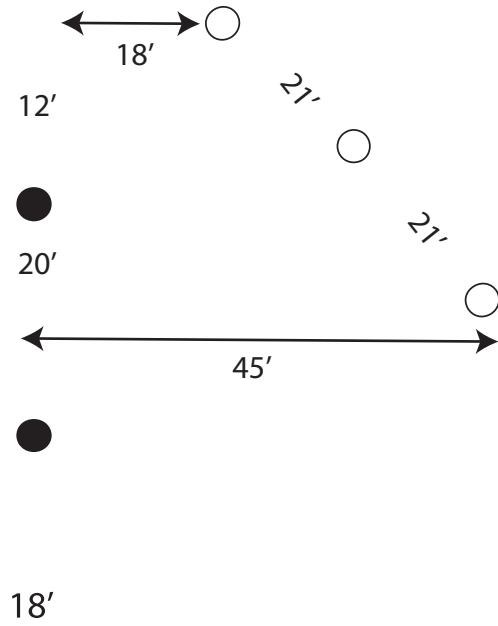
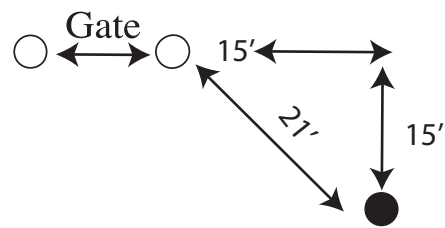

Start/Finish

#93

H. Engage the entire Random course first, then round the Rundown barrel.
 Procedural: 2, 3

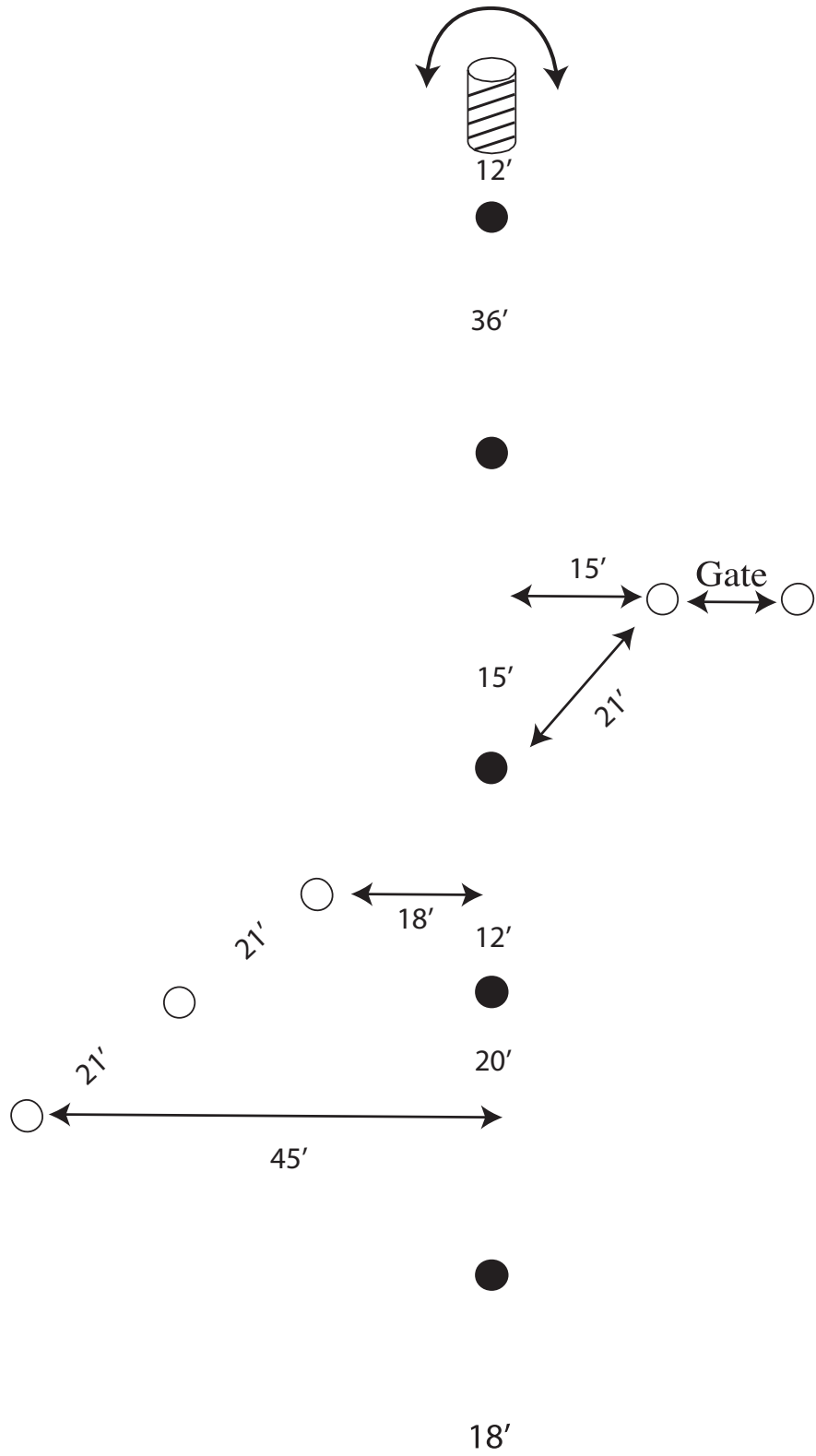

Start/Finish

#94

H. Engage the entire Random course first, then round the Rundown barrel.

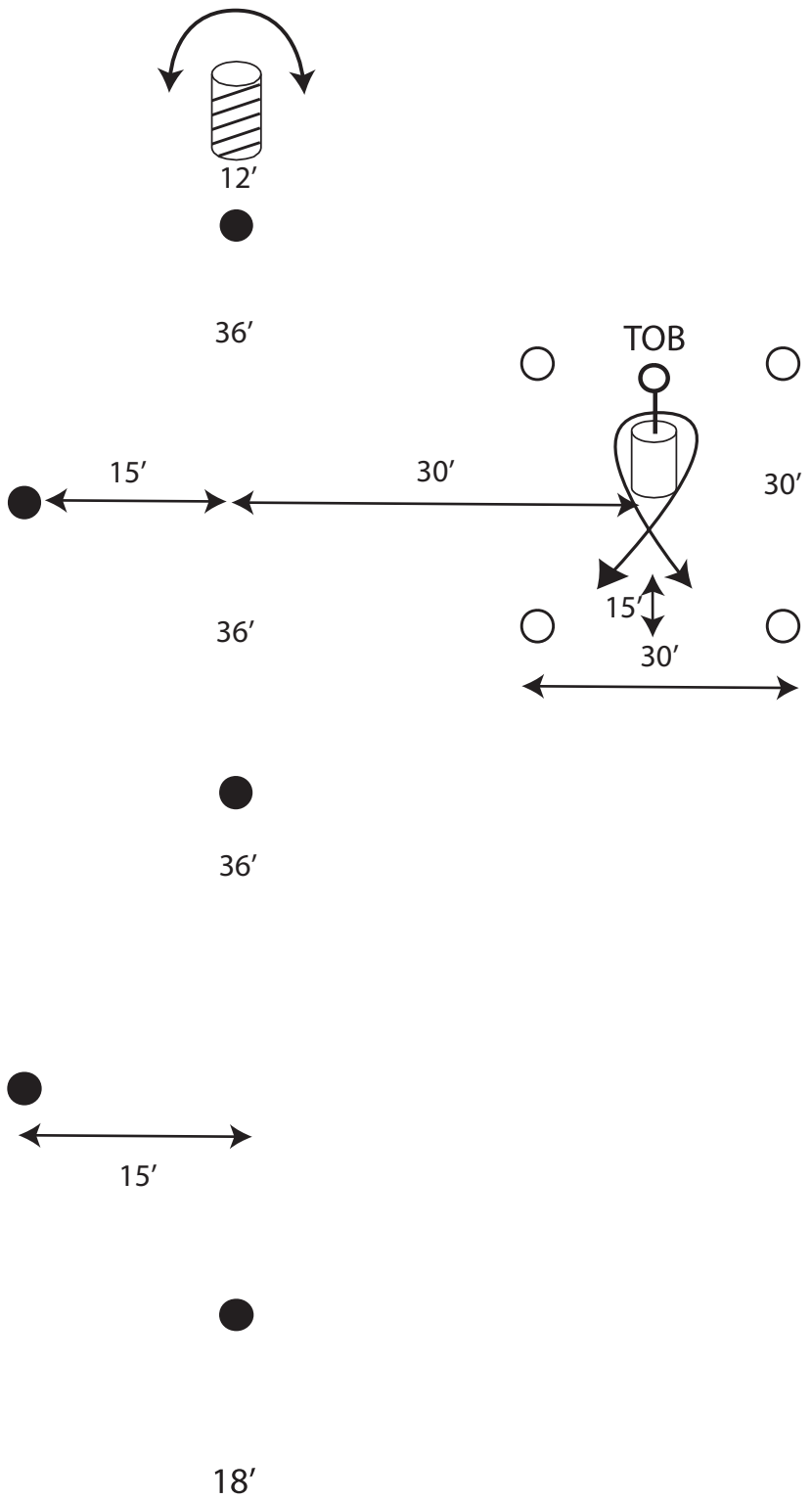

Start/Finish

#95

C. Engage 5 of one color, round the barrel, engage 5 of the other color
 Procedural: 2, 3

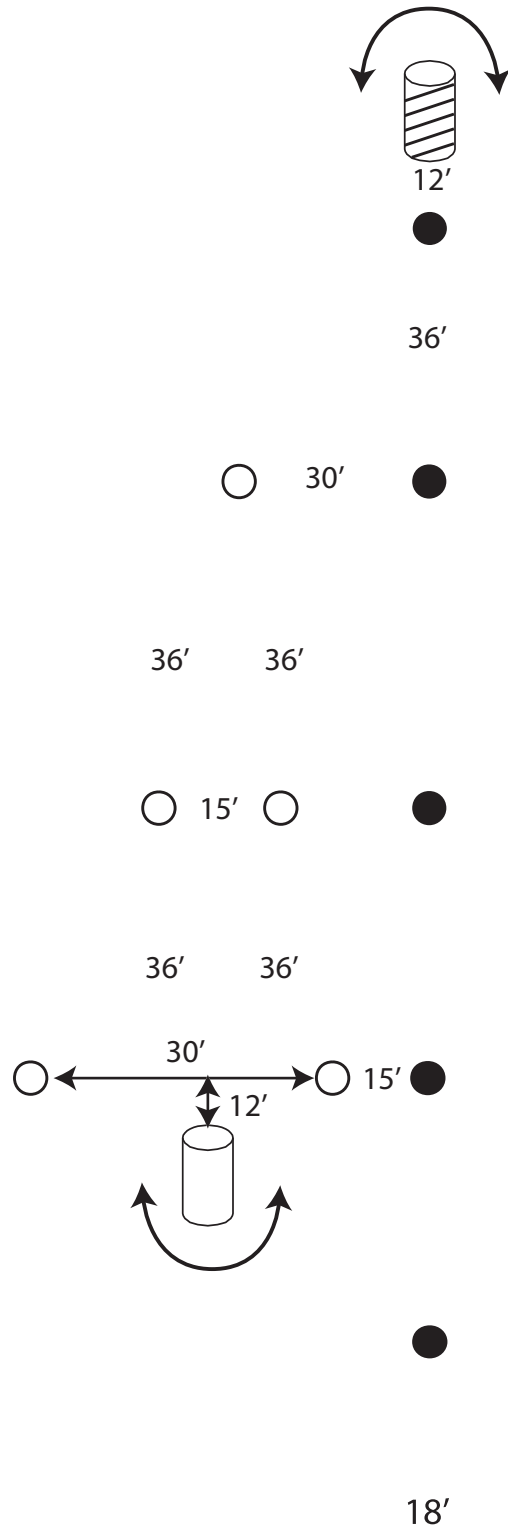

Start/Finish

#96

B. Engage the entire Random course first, then round the Random barrel
 Procedural: 2, 3

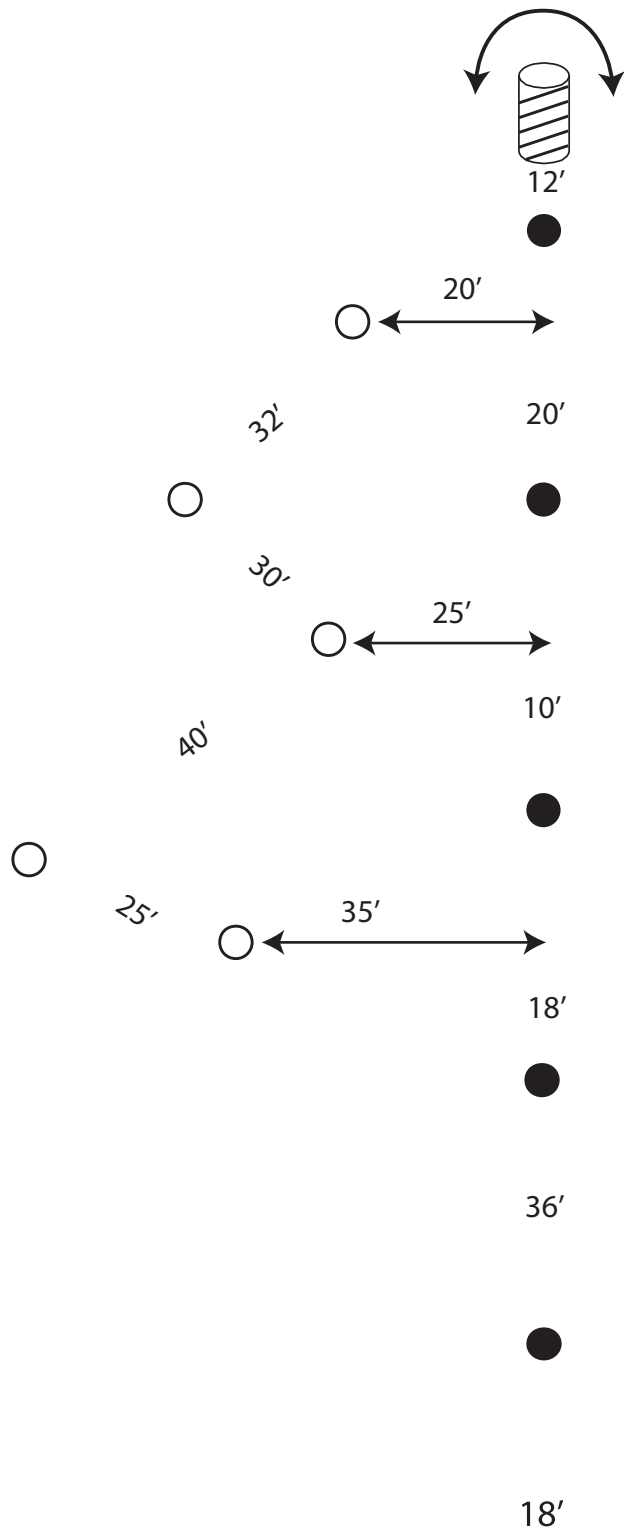

Start/Finish

#98

E. Engage all light targets first, then round the Rundown barrel.
 Procedurals: 2, 3

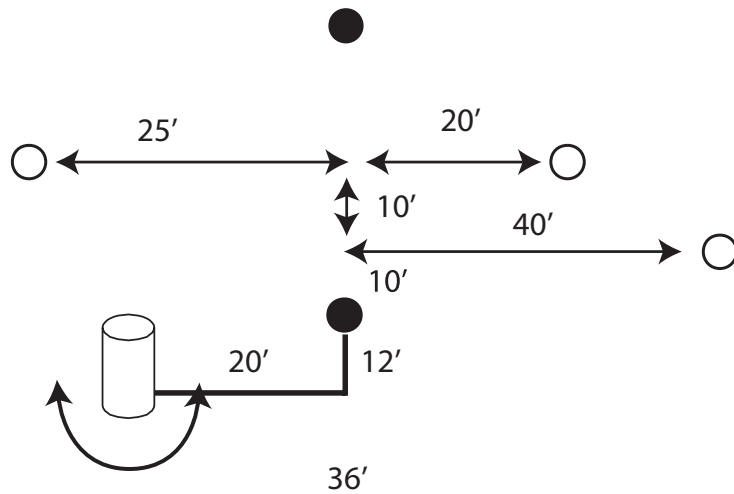
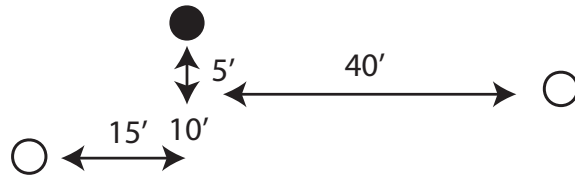
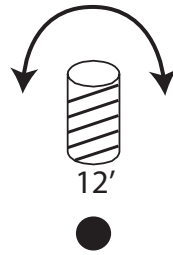

Start/Finish

#99

B. Engage the entire Random course first, then round the Random barrel.

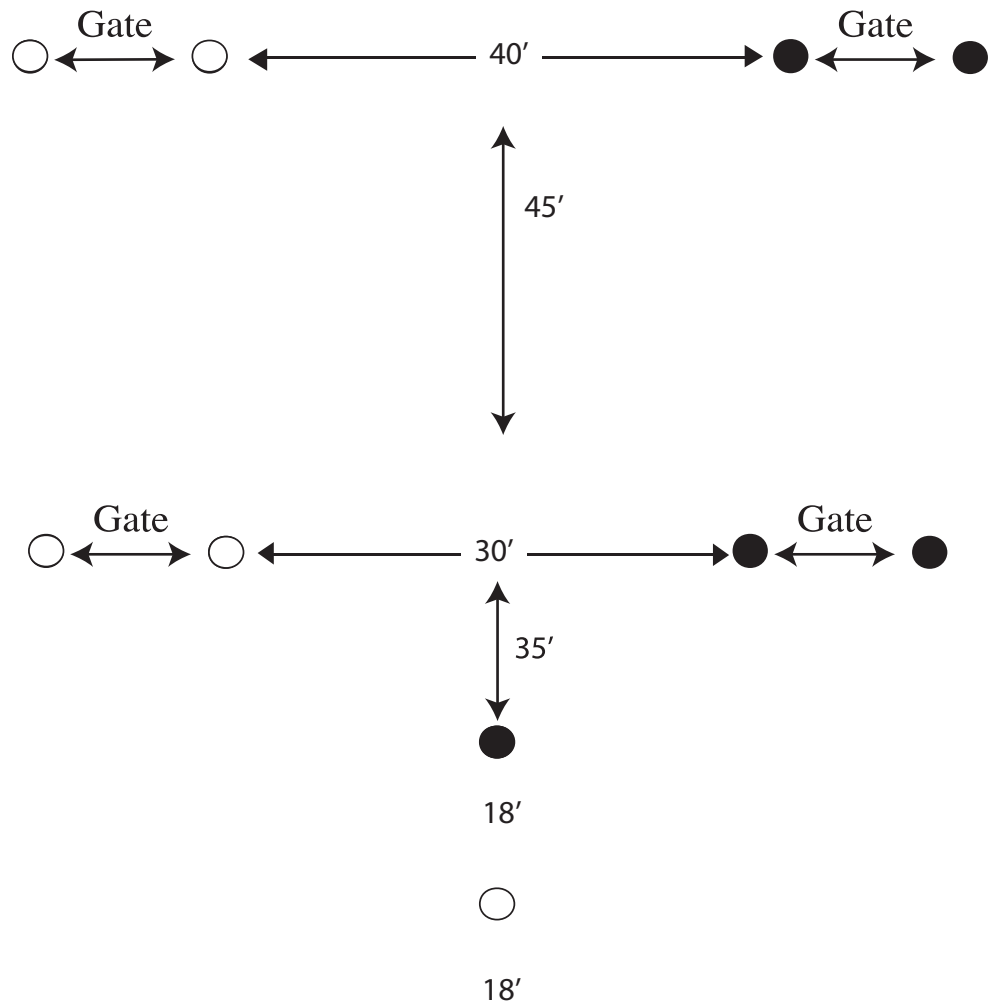

Start/Finish #101

F. Engage 5 of one color, then engage 5 of the other color.
 Procedurals: 1, 2, 3

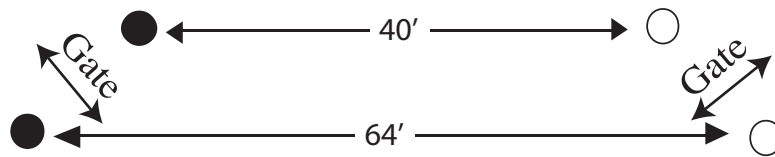

35'



35'

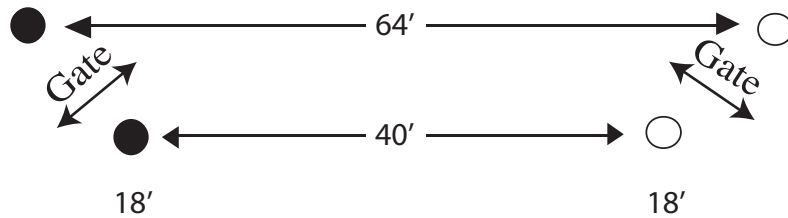

Start/Finish

#102

F. Engage 5 of one color, then engage 5 of the other color.
 Procedurals: 1, 2, 3

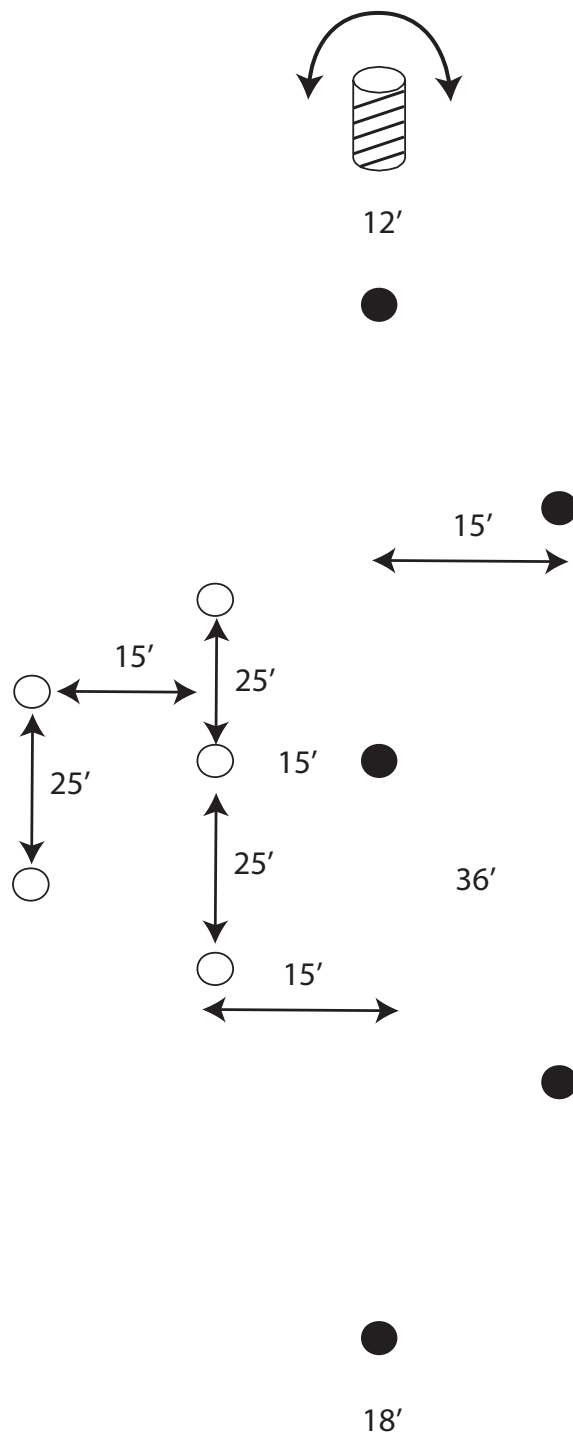

Start/Finish

#103

E. Engage all light targets first, then round the Rundown barrel.

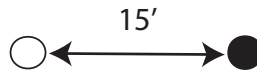
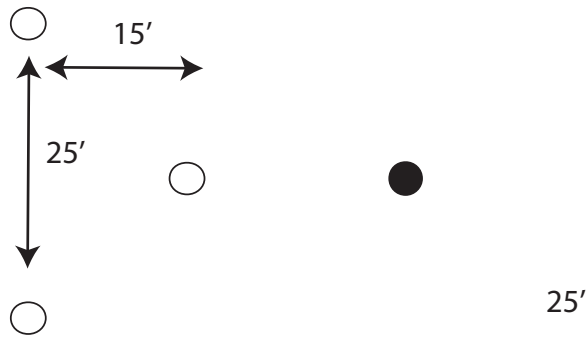
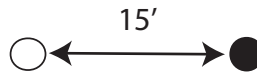
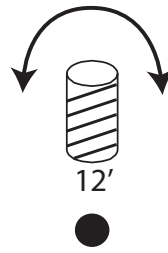

Start/Finish

#104ss

E. Engage all light targets first, then round the Rundown barrel.
 Procedural: 2, 3

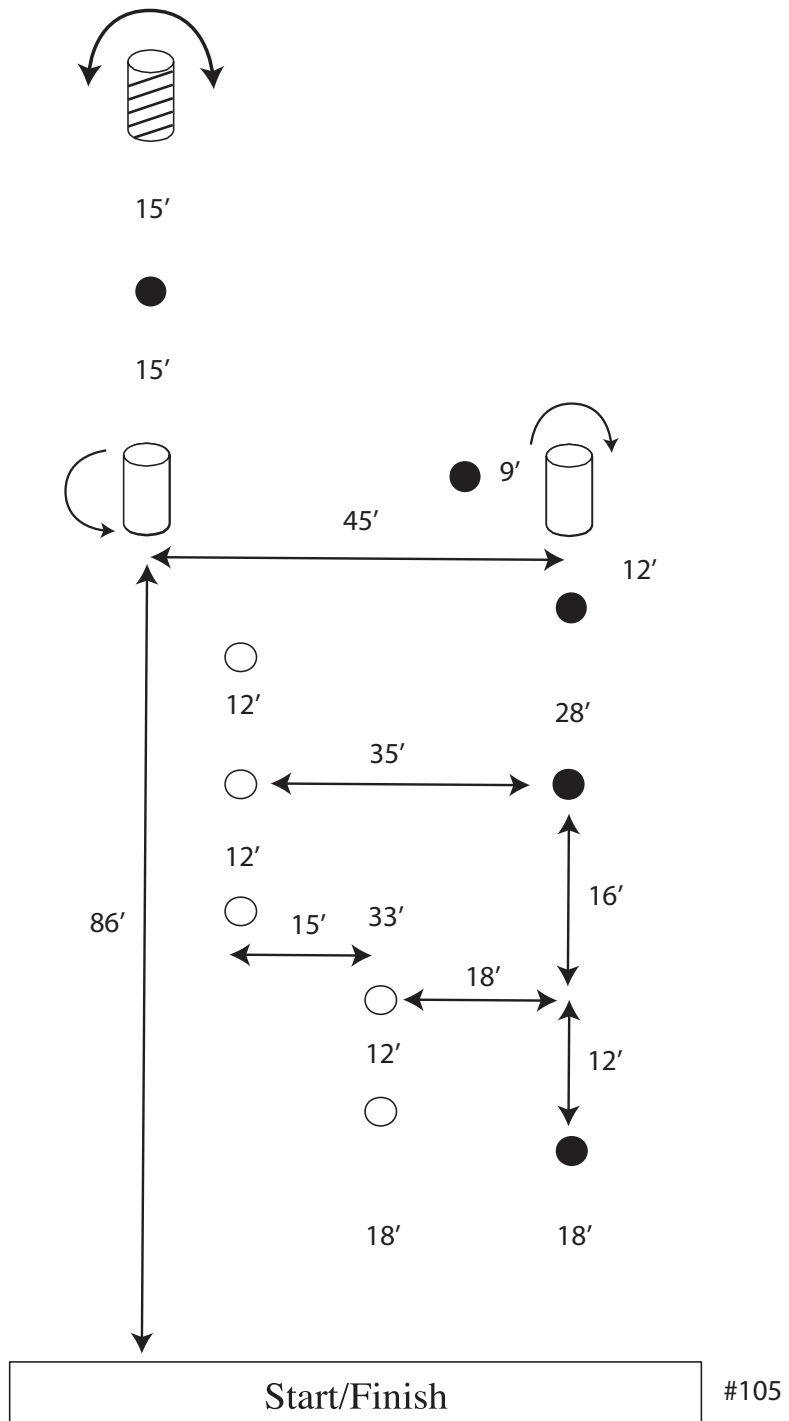

E. Engage all light targets first, then round the Rundown barrel, and engage dark targets and random barrels.
 Procedurals: 2, 3

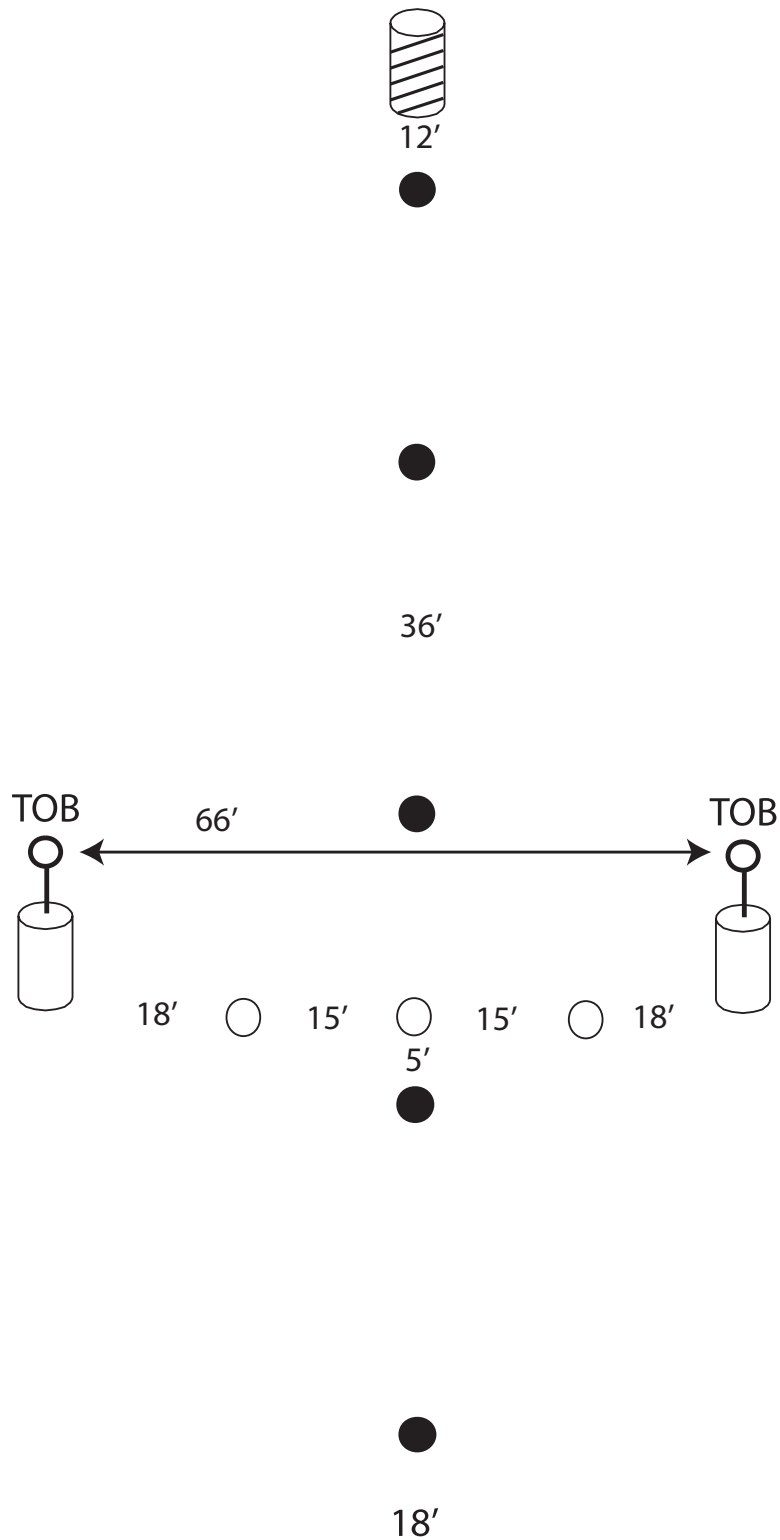

Start/Finish

#106

Contestant may start on either side of the right or left barrel.

When starting with the right barrel, there will be one right turn and two left turns.

When starting with the left barrel, there will be one left turn and two right turns around barrels.

H. Engage the entire Random course first, then round the Rundown barrel.

Procedurals: 2, 3. Rifle/Shotgun Course

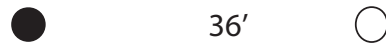
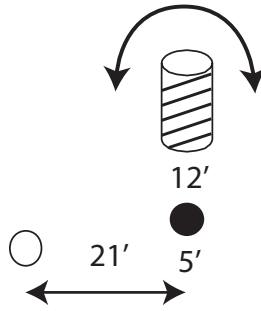

25'

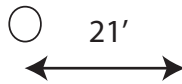

18'



9'

Start/Finish

#107ss

E. Engage all light targets first, then round the Rundown barrel.
 Procedurals: 2, 3